



Quick Reference Catalog - L20024

A Fleet Catalog of our Highest Volume Part Numbers (5/12)



Haldex

Innovative Vehicle Solutions
www.haldex.com

Important Notice

The products described within this literature, including without limitation, product features, specifications, designs, availability and pricing are subject to change by Haldex and its subsidiaries at any time without notice.

This document and other information from Haldex, its subsidiaries and authorized distributors provide product and/or system options for further investigation by users having technical expertise. It is important that you analyze all aspects of your application and review the information concerning the product or system, in the current literature or catalog. Due to the variety of operating conditions and applications for these products or systems, the user, through their own analysis and testing, is solely responsible for making the final selection of the products and systems and assuring that all performance, safety and warning requirements are met.

Table of Contents

DESCRIPTION	PAGE
New & Remanufactured Compressors, Kits, Governors & Air Cleaner	2 - 4
Air Valves	5 - 11
Suspension Valves	12 - 14
Actuators, Maxibrakes, Service Chambers, Replacement Parts	15 - 18
Electrical Products, Switches, Primary Wire, Brake Controllers, Battery Hardware	19 - 24
Air Treatment Products	25 - 26
Gladhands, Reservoirs, Air Hoses, Flexastiks	27 - 29
Brake Adjusters (Manual, AA1, SABA)	30 - 31
Water Pumps (New & Remanufactured)	32
Anti-Lock Brake Systems (ABS)	33 - 36
New & Remanufactured Clutches	37 - 42
Remanufactured Products: Alternators, Starters, Fan Clutches, Brake Calipers, Steering Gears & Pumps, Air Wiper Motors, Air Control Valves, Vacuum Boosters	43 - 45
Brake Hardware Kits	46
Brake Block/Lined Shoe Descriptions	47
Brake Shoes (Most Popular Styles)	48 - 51

Copyright 2012
Haldex Brake Products Corporation
10930 North Pomona Avenue
Kansas City, Missouri 64153

All rights reserved.
Materials may only be reproduced with written permission of Haldex.

Any Part Number throughout this Catalog with a Suffix "X" is Considered a Remanufactured Part.

Remanufactured Haldex Compressors



EL740 - 7.4 CFM



EL850 - 8.5 CFM



EL1300 - 12.9 CFM



EL1600 - 16.1 CFM



EL3200 - 32.2 CFM

Haldex air compressors are designed for use in heavy duty vehicle air brake systems.

The EL1300/EL1600 are water cooled, two-cylinder, reciprocating piston type

compressors designed for high performance with maximum durability for extended life.

The EL1600 is identical to the EL1300 except for the increased stroke which is achieved by increasing the crankshaft throw. The height of the compressor is increased by .19 inches.

The EL3200 is two twin cylinder EL1600 compressors assembled in-line and is designed for use on vehicles with a high air volume requirement for special accessory equipment requirements in addition to the air brake system.

The EL850 is a single cylinder compressor offered in water-cooled or air-cooled versions.

The EL740 compressors are offered in water-cooled or air-cooled versions and accommodate belt-driven or gear-driven mounting requirements for most gasoline and diesel engines.

All compressors are available remanufactured. Some older EL compressors may not be available in new product and may only be available in remanufactured form.

Identification Information

REMANUFACTURED PART NUMBERS

Any part number throughout this catalog with the "X" Suffix is considered a Remanufactured Part.

COREFREE™ PART NUMBERS

Any part number throughout this catalog with the "RX" Suffix is CoreFree™. These parts require no core.

COMPRESSOR PORTING REFERENCES

Porting references on Bendix Compressors are looking at the "non-drive" end of the compressor.

Porting references on Haldex Compressors are looking at the drive end of the compressor. Heads on Haldex Compressors may be rotated unless otherwise noted.

Flange and Engine

ENGINE -

Standard Belt Drive

PART



with Spec. Ford Bottom Plate

EL13022RX, EL13022X

Standard Belt Drive

EL13060X

Standard Belt Drive

EL16060X

Air Cooled Single Cylinder

KN85020X

Water Cooled Single Cylinder

KN86020X

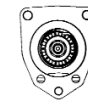

Caterpillar 1673, 1674, 3406B

EL13080X
EL13081X
EL16080X

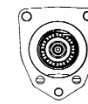

Caterpillar 3406-E240 Spline

EL13120RX, EL13120X
EL16120X

Caterpillar 3406-E324 Taper

EL13170X

Caterpillar 3406B-E324 Taper

EL13200RX, EL13200X
EL16200RX, EL16200X

Mack In-Line Six
(*Do Not Turbo-Charge
Mack Compressors)

EL13111RX*, EL13111X*
EL14111X
EL16111RX, EL16111X

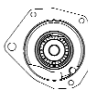

Caterpillar 3306

EL13151RX, EL13151X



Cummins In-Line
(Double Flange)

EL13040RX, EL13040X
EL16040RX, EL16040X

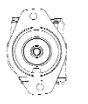

Cummins Type "B" Engines

KNT85230X
KNT86230RX
KNT86230X

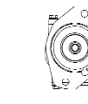

Cummins Type "C" Engines

EL13220X



Detroit Diesel 0°

EL13050RX, EL13050X
EL16050RX, EL16050X



Detroit Diesel 41°

EL13090X

Detroit Diesel 45°

EL13160X
EL16160X

Detroit Diesel 50°

EL13100RX, EL13100X
EL16100RX, EL16100X

Detroit Diesel 75°

EL16250X



Detroit Diesel 60 Series

EL13312RX, EL13312X
EL16312X

Remanufactured Competitor Compressors

BENDIX®



103274X



109139X



109429X



109430X



286528RX
286528X

PART #	Model	Description	Cooling	Air Inlet	Air Outlet	Notes
103274X	TF501	CAT 3406B - Flange Mount	Water/Air	Left	Top	Threaded Discharge
109139X	TF550	CAT 3406,C10,C12,C15,C16-Flange Mt.	Water	Left	Left/Top	Crankshaft Thread
109429X	TF550	Detroit 0° Tilt - Flange Mount	Water/Air	Right	Top/Right	60 Series Adapterless
109430X	TF750	Detroit 0° Tilt - Flange Mount	Water/Air	Right	Top/Right	60 Series Adapterless
286528RX	TF501	Base Mount - CoreFree™	Water/Air	Left	Top	Threaded Discharge
286528X	TF501	Base Mount	Water/Air	Left	Top	Threaded Discharge

CUMMINS



3018543X



3049186X



3558052X



3558072X



3558074X

PART #	Model	Description	Air Inlet	Air Outlet	Unloader Port/Type	Notes
3018543X	SS296 Super Single Cyl.	Cummins Std. Case	Left	Rear	Left/Direct	For L/K/N Engines
3049186X	SS296 Super Single Cyl.	Cummins Std. Case	Left	Rear	Left/Direct	Square Flange Crank.
3558052X	QE296C Econo Single Cyl.	Cummins C-Series	Left	Front	n/a	Iron Head/Cover
3558072X	QE296 Econo Single Cyl.	Cummins L10/N14	Left	Rear	n/a	Iron Head/Cover
3558074X	QE338 Econo Single Cyl.	Cummins E - Std. Case	Left	Rear	n/a	Iron Head/Cover

WABCO



9111535100X



9111535200X



9111535300X



9111535400X



9111535410X

PART #	Model	Description	Bore Size	Water* Port	Discharge* Port	Governor* Port
9111535100X	SS318	Cummins ISX	85MM	M18 - 1.5 STOR	M27 - 2.0 STOR	M10 - 1.0 STOR
9111535200X	SS318	Cummins L, M, N	85MM	3/4" - 16 STOR	M27 - 2.0 STOR	M10 - 1.0 STOR
9111535300X	SS318	Cummins ISC, Thru Drive	85MM	3/4" - 16 STOR	M27 - 2.0 STOR	M10 - 1.0 STOR
9111535400X	SS318	Ext. Flange w/Gear, Thru Drive	85MM	3/8" NPT	1/2" NPT	1/8" - 27 NPT
9111535410X	SS318	Ext. Flange w/Gear, Non-Thru Drive	85MM	3/8" NPT	1/2" NPT	1/8" - 27 NPT

* STOR - Straight Thread O-Ring

Compressor Kits / Air Governor

MANIFOLD KIT (INTAKE)

- Hose - 3/4"
- Mounting centers - 2.75

PART NUMBER
SN3711AD



DISCHARGE HOSE ASSEMBLY (FLEXIBLE)

- 1/2" I.D.
- Ferrule and nut included
- For easy changeover from a Bendix® side mount discharge to a top discharge Haldex Compressor

PART NUMBERS
KN17500 - 18"
KN17501 - 24"
KN17503 - 48"
KN17504 - 60"



COMPRESSOR INSTALLATION KIT

- For EL1300/EL1600 Compressors

PART NUMBER
SN144

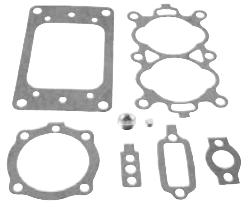

INLET CHECK VALVE

- For EL1300/EL1600 Compressors

PART NUMBER
SN3711AJ



MANIFOLD KIT (DISCHARGE)

- For all EL1300/EL1600 Compressors

PART NUMBERS

SN3711AH - Side Outlet
SN3711J - Threaded
SN3711K - Right Hand
SN3711L - Left Hand



SN3711AH



SN3711J



SN3711K



SN3711L

PISTON TYPE GOVERNOR

- Direct compressor or remote mount
- 1/8-27 NPT ports
- .336 Diameter mounting holes
- Cut-in pressure of 105 PSI normal
- Cut-out pressure of 130 PSI normal



PART NUMBER
KN18530 (new)

REMANUFACTURED D-2 STYLE GOVERNOR

- Standard unit
- 1/8" ports
- Cut-in pressure of 105-110 PSI normal
- Cut-out pressure of 15-30 PSI above Cut-in



PART NUMBER
275491RX (CoreFree™)

Air Cleaners

- Large capacity
- Provides greater atmospheric air intake capacity
- Suitable for mounting on Haldex and competitive model compressors

PART #	DESCRIPTION
100696E	Filter Only
KN19040	Assembly with Filter



Most Haldex Valves are available in New, Remanufactured and CoreFree®.
Please consult the Haldex Master Catalog (www.haldex.com) for our complete listing.

Relay Valves

- Used to apply and release service brakes on tractor or trailer
- Cover may be rotated without affecting performance or warranty
- Valves are supplied with and without brackets (Brackets may be purchased separately)

RG2 - TWO PORT TRAILER VALVE

- Compact size
- Control position is in relationship to delivery ports
- Mounting .34" on 1 1/2" centers
- Crack Pressure 5.6 +/- 1.0 PSI



PART #	SUPPLY	DELIVERY	CONTROL POSITION
KN28500	(2) 3/8"	(2) 3/8"	90°
KN28510	3/8" & 1/2"	(2) 3/8"	90°
KN28514X*	1/2" & 3/8"	(2) 3/8"	90°
KN28520	(2) 1/2"	(2) 1/2"	90°
KN28531	1/2" & 3/8"	(2) 3/8"	0°

* Available Remanufactured or CoreFree™ only.

RG5 - TWO PORT TRAILER VALVE

- Used on 2 tank, 3 valve trailer system and tractor applications
- Made of durable EGC (Engineering Grade Composite)
- Crack Pressure 6.0 PSI



KN28550 shown

PART #	SUPPLY A	SUPPLY B	DEL.	CONTROL
KN28550	1/2" x 3/8" Nipple	Plugged	(2) 3/8"	1/4"
KN28043	Plugged	3/8"	(2) 3/8"	1/4"

TWO PORT FAST AIR AND BALANCING (FAB)

- Speedup or fast air relay
- Used on converter dollies, long wheel base and towing trailers to accelerate control signal and meet FMVSS121 pressure differential requirements
- Cover may be rotated without affecting performance or warranty



PART #	SUPPLY	DEL.	CONTROL	CRACK PRESSURE
KN28300	(2) 1/2"	(2) 1/2"	3/8"	0 PSI

TWO AND FOUR PORT SINGLE CONTROL LINE

- Used to apply and release service brakes on tractor or trailer
- Crack Pressure 4.6 PSI

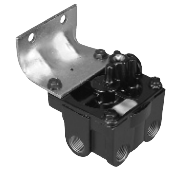

KN28131 shown

PART #	SUPPLY	DELIVERY	CONTROL	PORTS
KN28042	(2) 1/2"	(4) 1/2"	1/4"	4
KN28131	(2) 1/2"	(2) 1/2"	1/4"	2
KN28140	(2) 1/2"	(2) 1/2"	1/4"	2

TWO AND FOUR PORT WITH ANTI-COMPOUNDING

- Built-in anti-compounding two-way check valve for spring brake control
- Crack Pressure 4.6 PSI



KN28041 shown

PART #	SUPPLY	DELIVERY	CONTROL	PORTS
KN28041	(2) 1/2"	(4) 1/2"	2 (1/4")	4
KN28043	(2) 1/2"	(2) 1/2"	3/8" & 1/4"	2
KN28071	(2) 1/2"	(2) 1/2"	1/4" & 1/8"	2

TWO PORT WITH INTEGRAL BRACKET

- Used to apply and release service brakes on tractor or trailer



KN28060 shown

PART #	SUPPLY	DEL.	CONTROL	CRACK PRESSURE
KN28060	(2) 1/2"	(2) 3/8"	3/8"	4.6 PSI
KN28061	(2) 1/2"	(2) 1/2"	3/8"	4.6 PSI
KN28132	(2) 1/2"	(2) 1/2"	3/8"	7.0 PSI

FOUR PORT WITH INTEGRAL BRACKET

- Used to apply and release service brakes on tractor or trailer



PART #	SUPPLY	DEL.	CONTROL	CRACK PRESSURE
KN28080	(2) 1/2"	(4) 3/8"	3/8"	7.0 PSI
KN28085	(2) 1/2"	(4) 3/8"	3/8"	4.6 PSI

Relay Valves (cont'd)

RELAY VALVE - FOUR (VERTICAL) PORTS - SINGLE CONTROL

- For tractor or trailer application
- Four delivery ports facing down
- Low differential - high capacity
- Available in Remanufactured
- 3.0 PSI crack pressure



PART #	SUPPLY		DEL.	CONTROL
	A	B		
A103600	3/4"	Plugged	(4) 3/8"	1/4"
A86472*	3/4"	Not Drilled-No Threads	(4) 1/2"	1/4"
A86473	1/2"	Not Drilled-No Threads	(4) 1/2"	1/4"
A86477	3/4"	Plugged	(4) 1/2"	1/4"

* Available New only.

Isolation Valve

- Used in conjunction with a turbo-charged air compressor
- Added fuel economy and greater engine efficiency

PART #
KN23500



Trailer Valves

FF2 - FULL FUNCTION VALVE

- Single valve trailer system combines a pressure protection valve, two one-way check valves, spring brake valve with quick release and a four port relay valve
- Easy to install, maintain and troubleshoot
- Meets FMVSS-121 anti-compounding requirements
- Available in Remanufactured and CoreFree™



PART#	RES.	SUPPLY	CNTRL.	DEL.	PRIORITY
KN28600	3.0 Crack Pressure; Res. 3/4"; Cont. 1/4"; Sup. 3/8"; Spring Brake 2 @ 3/8" Del. (4) 3/8"				
KN28601	3.0 Crack Pressure; Res. 1/2"; Cont. 1/4"; Sup. 3/8"; Spring Brake 2 @ 3/8" Del. (4) 3/8"				
KN28602*	5.0 Crack Pressure; Res. 3/4"; Cont. 1/4"; Sup. 3/8"; Spring Brake 2 @ 3/8" Del. (4) 3/8"				
KN28603*	5.0 Crack Pressure; Res. 1/2"; Cont. 1/4"; Sup. 3/8"; Spring Brake 2 @ 3/8" Del. (4) 3/8"				

* Not available in CoreFree™.

TRAILER BRAKE CONTROL VALVE

- Made of Engineering Grade Composite (EGC)
- Light weight; withstands high impact
- Integral anti-compounding
- Black Cover - Service Brake
- White Cover - Spring Brake



PART#	RES.	SUPPLY	CNTRL.	DEL.	PRIORITY
KN26110	1/2"	3/8"	3/8"	(4) 3/8"	Service Brake
KN26120	1/2"	3/8"	3/8"	(4) 3/8"	Spring Brake
KN26121	1/2"	3/8"	3/8"	(4) 3/8"	Service Brake

EMERGENCY RELAY VALVES

- Pre-121 trailers, converter dollies or exempt trailers
- Crack Pressure: New - 3.0 PSI
Reman/CoreFree™ - 4.5 PSI
- KN30100 - auto. bleed down feature
- KN30200 - non-charging
- KN30300 and KN30400 - charging



PART #	SVC. INLET	EMER. INLET	DEL. (4)	AUX. RES.	RES.
KN30100	1/4"	1/4"	1/4"	Plugged	3/4"
KN30200	3/8"	3/8"	3/8"	1/2"	Plugged
KN30300	1/4"	1/4"	1/4"	Plugged	3/4"
					w/nipple
KN30400	1/4"	1/4"	3/8"	Plugged	3/4" Fem. w/nipple

RT-4 MULTI-FUNCTION TRAILER VALVES

- Used on trailers to control both parking and emergency brake functions
- KN26000X - Closing PPV 55 PSI
- KN26010/KN26020 - Closing PPV 70 PSI
- Meets FMVSS-121 trailer requirements



PART #	RES.	SUPPLY	CNTRL.	DEL.	PRIORITY
KN26000X*		Trailer Supply: (2) 3/8"; Trailer Control: 3/8"			
		Reservoir 1/2" & 3/8"; Delivery: (4) 3/8"			
KN26010		Trailer Supply: 3/8" & Plugged;			
		Trailer Control: 3/8"; Reservoir 1/2" & 3/8";			
		Delivery: (4) 3/8"			
KN26020		Trailer Supply: (2) 3/8"; Trailer Control: 3/8"			
		Reservoir 1/2" & 3/8"; Delivery: (4) 3/8"			

* Available Remanufactured or CoreFree™ only.

Most Haldex Valves are available in New, Remanufactured and CoreFree®.
Please consult the Haldex Master Catalog (www.haldex.com) for our complete listing.

Hand Operated Valves

MANIFOLD DASH VALVE

- Replacement for the MV2/MV3 Valve
- One piece construction provides no center body leakage
- Made of durable Engineering Grade Composite (EGC)



PART #	PORTS	DESCRIPTION
KN20607	3/8" PTC	Vertical Mount; M6 Metric Nuts on Cover
KN20611	1/4"	Horizontal Mount; 1/4"-20 Well Nuts in Body
KN20615	1/4"	Horizontal Mount; 1/4" Hole in Body
KN20616	1/4"	Vertical Mount; 1/4"-20 Well Nuts in Body

PUSH-PULL HOSTLER VALVE

- Panel or bulkhead mount
- Requires 3/4" hole in dashboard



PART #	DESCRIPTION
KN20010	1/4" Ports; 25/40 PSI Pop Press.; Plain Knob
KN20011	1/4" Ports; 0 PSI Pop Press.; Plain Knob
KN20015	1/4" Ports; 25/40 PSI Pop Press.; Trailer Emergency Knob

PUSH-PULL PARKING BRAKE VALVE

- Replacement for the PP-1 Valve
- Bulkhead mount - 7/8"
- Made of durable Engineering Grade Composite (EGC)
- Pop Pressure-35+/-10 PSI
- Knob Included



PART #	DESCRIPTION
KN20021	1/8" NPT Ports; System Brake
KN20022	1/8" NPT Ports; Parking Brake

FLIPPER STYLE PANEL MOUNT

- Panel or remote mount
- Made of durable Engineering Grade Composite (EGC)
- An on-off, non-automatic two position valve
- Chrome Handle; All Ports 1/8"



PART #	MOUNTING HOLES
KN20001	#10-24 with 1.50" Centers
KN20002	M5 Metric with 1.50" Centers

PP-8 REPLACEMENT VALVE

- Replacement for the PP-8 Valve
- Controls tractor only parking
- Made of durable Engineering Grade Composite (EGC)
- Bulkhead mount - 7/8"



PART #	DESCRIPTION
KN20035	All Ports 1/8"-27 NPT

PP-7 REPLACEMENT VALVE

- Replacement for the PP-7 Valve
- Controls Tractor Protection Valve
- Made of durable Engineering Grade Composite (EGC)
- Bulkhead mount - 7/8"



PART #	SUP.	CNTRL.	DEL.	EXH.
KN20025	1/8" NPT	1/8" NPT	1/4" NPT	1/4" NPT

PUSH-PULL PANEL MOUNT VALVE

- Panel mount
- All Ports are 1/4"
- Made of durable Engineering Grade Composite (EGC)



PART #	POP PRESSURE
KN20031	25-35 PSI
KN20033	7-17 PSI

Most Haldex Valves are available in New, Remanufactured and CoreFree®. Please consult the Haldex Master Catalog (www.haldex.com) for our complete listing.

Drain Valves

AUTOMATIC DRAIN VALVE

- Expels moisture with each brake application
- Removes excess moisture and contamination from "wet" tank
- Performs independently from compressor cycling
- Direct replacement for Bendix® DV2
- Built in heater prevents valve freeze-ups
- Built in filter protects valve against contamination

PART #	DESCRIPTION
KN24000	Not Heated
KN24001	Heated - 12 Volt
41010019	Heated - 12 Volt
41010021	Heated - 24 Volt



MANUAL DRAIN VALVE

- Manual wet or dry tank drain valves
- Cable is looped on both ends for easy hand hold
- All models have 1/4-18 threads
- Vibra-Seal™ applied to threads



HIGH PROFILE PART #	LOW PROFILE PART #	
12100	KN21100	No Cable
12103	KN21103	3' Cable
12104	KN21104	4' Cable
12105	KN21105	5' Cable

Quick Release Valves

QUICK RELEASE VALVE

- Made of durable Engineering Grade Composite (EGC)
- Lightweight



PART #	INLET	OUTLET	PSI DIF.
KN32003	1/2"	3/8"	3
KN32005	3/8"	3/8"	0
KN32011	1/2"	3/8"	0
KN32013*	1/2"	3/8"	0
KN32060	3/8"	3/8"	6

* Extra life QR Valve with dirt exclusion seal.

QUICK RELEASE VALVE W/TWO-WAY CHECK

- Used in spring brake control circuits to prevent compounding on trucks and tractors
- Replaces two valves with one



PART #	CNTRL.	DEL.
KN32040	1/4"	1/4"
KN32041	1/4"	3/8"

Pressure Relief Valve

- Non-adjustable
- Made of brass and stainless steel
- Factory set at 150 PSI

PART # (A)-Air Lines	PART # (B)-Reservoirs
KN31400 - 1/4"	KN31200 - 1/4"
KN31450 - 3/8"	KN31250 - 3/8"
KN31300 - 1/2"	

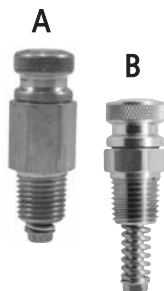

Soleonid Valve

- Used to operate the shift mechanism of a two speed axle

PART #	DESCRIPTION
KN68230	12 Volt
KN68237	24 Volt

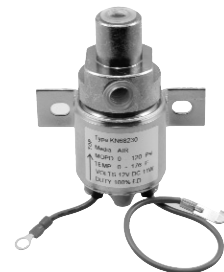

Most Haldex Valves are available in New, Remanufactured and CoreFree®. Please consult the Haldex Master Catalog (www.haldex.com) for our complete listing.

Tractor Protection Valves

TRACTOR PROTECTION VALVE TWO AND THREE LINE - AUTOMATIC

- Equipped with built-in quick release to improve trailer timing
- Eliminates the need for a separate valve
- Interchangeable with most competitive units

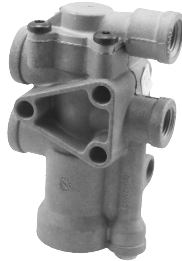

PART #	DESCRIPTION
KN34030	2-Line
KN34050	3-Line w/Snorkel Exhaust
KN34070	3-Line w/o Quick Release
KN34071	3-Line

Port orientations detailed in Haldex Master Catalog (www.haldex.com).

TRACTOR PROTECTION VALVE MANIFOLD TYPE - NON-AUTOMATIC

- Includes tractor protection, two double check valves, stoplight switch port and built-in quick release.



PART #	DESCRIPTION
KN34110	2-Line; No Exhaust
KN34111	2-Line; w/Exhaust Tube

Port orientations detailed in the Haldex Master Catalog (www.haldex.com).

TRACTOR PROTECTION VALVE- TWO LINE NON-AUTOMATIC

- Must be used with Pressure Sensing Dash Control Valve
- Built-In Quick Release



PART #	TRAC. SERV.	TRAC. EMER.	TRLR. SERV.	TRLR. EMER.
KN34060	3/8"	1/4"	1/2"	1/2"
KN34061*	3/8"	1/4"	1/2"	1/2"

*Exhaust Fitting

Inversion Valve

- Used with spring brake equipped trucks
- Complies with FMVSS-121 regulations
- Detects primary control line failure, allowing modulated control of spring brake
- Interchangeable with competitive units without anti-compounding feature

PART #	PRIM. RES.	SUPPLY	CONTROL	DELIVERY	VERSION
KN28030	1/4"	1/4"	1/4"	1/4"	Pre-March 1998
KN28032	1/4"	1/4"	1/4"	1/4"	Post-March 1998
KN28034	3/8" PTC	3/8" PTC	3/8" PTC	3/8" PTC	Pre-March 1998



Most Haldex Valves are available in New, Remanufactured and CoreFree®. Please consult the Haldex Master Catalog (www.haldex.com) for our complete listing.

Pressure Protection Valves

Pressure Protection Valve

- E-coated zinc diecast body provides exceptional corrosion resistance
- Premium Nitrile diaphragm provides long life and reliability
- Durable design increases product life, reducing replacement costs
- Use in air suspensions, air seats and cab isolation systems



PART #	PORT SIZES	CLOSING PRESSURE	OPENING PRESSURE	FILTER
90554107	1/4" NPT	70 PSIG	75 PSIG Min.	Yes
90555397	1/4" NPT	80 PSI	85 PSI	No
90555398	1/4" NPT	90 PSI	95 PSI	No

Pressure Protection Valve with One-Way Check

- One-way check valve prevents reverse air flow
- Exceptional corrosion resistance



PART #	PORT SIZES	CLOSING PRESSURE	OPENING PRESSURE
90555409	1/4" NPT	65 PSI	70 PSIG
90555410	1/4" NPT	80 PSI	85 PSI
90555411	1/4" NPT	90 PSI	95 PSI

Foot Operated Valves

SINGLE CIRCUIT FOOT VALVE

- Used primarily with Pre FMVSS-121 vehicles
- Provides smooth and consistent pedal feel
- Interchangeable with most competitive units



PART #	DEL.	SUPPLY
KN22100	(4) 1/2"	(2) 1/2" (2) 1/4"

DUAL CIRCUIT FOOT VALVE

- Meets FMVSS-121 requirements
- Provides smooth and consistent pedal feel
- Interchangeable with most competitive units



PART #	DEL.	SUPPLY
KN22150	(4) 3/8"	(4) 3/8"

Check Valves

ONE-WAY CHECK VALVE

- Positive, long lasting valve for every application on trucks, tractors and trailers



PART #	PORTS
KN23000	1/2"
KN23010	3/8"
KN23040	3/4"
KN23060	1/2" 90° (Brass)

TWO-WAY CHECK VALVE

- Shuttle type valve, mounts horizontally
- Interchangeable with most competitive models



PART #	INLET	INLET	OUTLET	OUTLET
KN25080	3/8" M w/Nipple	3/8" F	3/8" F	1/4" F Reducer
KN25090	3/8" F	3/8" F	3/8" F	1/4" F Reducer

F = Female M = Male

Pilot Valve

- Activated by applying pilot pressure
- Remote mounted valve suited for any chassis location
- Typically used on auxiliary axle applications or to rapidly exhaust air suspensions

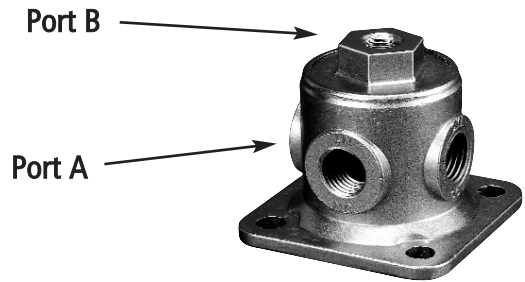

PART # 90554615	DESCRIPTION Port A - 1/4" NPT; Port B - 1/8" NPT
---------------------------	--

Remanufactured Competitive Valves

BENDIX® R-12 RELAY VALVE

PART #	SUPPLY	DELIVERY	CONTROL	EXHAUST	CRACK PRESSURE	
102626X	1/2"	(4) 1/2"	1/4"	-	4.0 PSI	

BENDIX® PP-1 HAND CONTROL VALVE

PART #	SUPPLY	DELIVERY	CONTROL	EXHAUST	CRACK PRESSURE	
276567X	1/8"	1/8"	-	1/8"	-	

Note: Automatic Release Pressure - 40 PSI.

BENDIX® E-6 DUAL CIRCUIT FOOT VALVE

PART #	SUPPLY	DELIVERY	CONTROL	EXHAUST	CRACK PRESSURE	
286171X	(4) 3/8"	(4) 3/8"	-	-	-	

BENDIX® RE-6 EMERGENCY RELAY VALVE

PART #	SUPPLY	DELIVERY	SVC.	EMER.	INTL. EMER. APPL. PRES.	MAX. EMER. REL. PRES.	
281865X	(1) 3/8"	(2) 1/4"	1/4"	1/4"	50±5 PSI	95 PSI	
	(1) 3/4"	(2) 3/8"					

BENDIX® QR-1 QUICK RELEASE VALVE

PART #	SUPPLY	DELIVERY	EXHAUST	CRACK PRESSURE	
229859X	3/8"	3/8"	-	1 PSI	

SEALCO RATIO RELAY TRAILER VALVES

PART #	SUPPLY	DELIVERY	RESERVOIR A	RESERVOIR B	CONTROL	 110170X 110500X
110170X	3/8"	(4) 3/8"	1/2"	1/2"	3/8"	
110500X	3/8"	(4) 3/8"	1/2"	3/8"	3/8"	

BENDIX® MV-3 (MANIFOLD) HAND CONTROL VALVE

PART #	RESERVOIRS	DELIVERY TRACTOR	DELIVERY TRAILER	EXHAUST	
65157X	(2) 1/4"	1/4"	1/4"	1/4"	

Controlled Response (CR) Height Control Valve

- Controlled response time delay technology maintains chassis position and conserves air to increase compressor life
- Robust diecast zinc body to ensure operation in extreme conditions
- Flexible right or left mounting options provide ease of installation and reduced inventories
- Optional integrated dump valve provides the ability to automatically or manually exhaust air from the suspension
- All Ports are 1/8" NPT



PART #	DUMP VALVE	FITTINGS
90054007	N/A	1/4"
90554114	N/A	No Fittings
90554147	N/A	Adapt 1/8" NPT to M10 x 1
90554183	N/A	3/8"
90554334	Norm. Open	1/4" and 3/8"
90554648	Norm. Closed	1/4" and 3/8"

Precision Response (PR) and PR Plus HCV

- Use of ceramic seal technology allows the valve to be very reliable and highly durable even in the most extreme conditions
- Non-time delay valve
- Tight dead zone
- Provides precise adjustment to ride height variation
- Normally Open Dump Valve



PART #	ARM	PORTS
90555318	7" Fixed	3-Port Side Manifold; Pilot Port 1/4" PTC; All Other Ports 3/8" PTC
90555353	7" Fixed	5-Port Side Manifold; Pilot Port 1/4" PTC; All Other Ports 3/8" PTC
90555375	7" Adjust.	3-Port Side Manifold; Pilot Port 1/4" PTC; All Other Ports 3/8" PTC
90555376	7" Adjust.	2-Port Straight Manifold; Pilot Port 1/4" PTC; All Other Ports 3/8" PTC
90555377	7" Adjust.	3-Port Straight Manifold; Pilot Port 1/4" PTC; All Other Ports 3/8" PTC
90555382	7" Adjust.	3-Port Straight Manifold; Pilot Port 1/4" PTC; All Other Ports 1/4" NPT

Suspension Dump Valves

PART #
90554335

DESCRIPTION
Optional Normally Open Dump Valve; Gold Body

PART #
90554902

DESCRIPTION
Optional Normally Closed Dump Valve; Silver Body



For CR Type HCV

COLAS® Raise/Lower Hand Valve

- Manual raise/lower hand valve for commercial vehicles and trailers
- Works with single or dual height control valve systems
- Horizontal or vertical installation with external mounting
- Optional automatic return to ride height makes valve error proof
- One component and fewer fittings reduces installation time
- Available with Push-To-Connect (PTC) fittings

PART #	DESCRIPTION
90555270	3/8" Push-To-Connect (PTC) Fittings
90555292	1/4" Push-To-Connect (PTC) Fittings



Suspension EGP HCV

- Dual or single circuit operation without extra ports or fittings
- High grade durable all plastic construction for corrosion protection
- Optional dump valve available
- 1/4" NPT fittings

PART #	DESCRIPTION
KN27000	Standard Flow with 14" Lever Arm
KN27013	High Flow with 14" Lever Arm
KN27201	Low Flow (Valve Only)
90555105	Standard Flow (IR Type Valve Only)
90555106	Standard Flow with Normally Open IR Type Dump Valve
42150003	Standard Flow with Dual Ride Height, IR Type; Vertical Arm 20"; Horizontal Arm 12"



ILAS® III Integrated Lift-Axle System Valve

- Provides precise operation of lift axles for commercial vehicles and trailers
- Manual version automatically lowers lift axle; lift axle is manually raised
- Automatic version automatically lowers and raises the lift axle
- Push-To-Connect (PTC) fittings
- Integrated mounting holes and solid structure allow for easy installation
- Replaces many lift axle systems which typically require multiple components and fittings

PART #	DESCRIPTION
90555288	ILAS® III Automatic Version
90555293	ILAS® III Manual Version



ILAS® E Integrated Lift-Axle System Valve

- Offers a cost effective installation for electronically controlled lift axles
- Simplified solutions reduce components and fittings
- Higher air flow provides faster response time of the lift axle
- Push-To-Connect (PTC) fittings
- Use with Haldex Trailer Roll Stability (TRS) or with manual electric switch
- DIN-Bayonet electrical connection
- Programmable through Haldex Trailer Roll Stability (TRS) for raising and lowering lift axle

PART #	DESCRIPTION
62101005	ILAS® E Lift Axle Valve Kit
90555326	ILAS® E Valve
814012131	ILAS® E Power Cable



Scale-O-Matic

PART #	DESCRIPTION
42123026	Enclosed Manual Switch, Pilot Valve And Silicone Filled Gauge
42123039	Silicone Filled Gauge with Calibration Decal
90554346	Large Weather Proof Enclosure Box
90554628	Small Weather Proof Enclosure Box



Consult the Haldex Master Catalog (www.haldex.com) for a complete listing of Scale-O-Matic products.

Linkage

- **Fixed Rod Linkage** must be ordered at the correct length Available in .025" increments from 4.5" to 19 5/8". To order a 14.25" linkage, specify the model number FB14.25-I, for a 16" linkage the model number would be FB16-I.
- **Fixed Loop Linkage** must be ordered at the correct length. Available in .025" increments from 4.5" to 19 5/8". To order a 10.5" linkage, specify the model number LP10.5-I, for a 12" linkage the model number would be LP12-I.

PART #	DESCRIPTION
48100225	Adjustable Linkage Model SRK 168; 19 5/8" Maximum



Consult the Haldex Master Catalog (www.haldex.com) for a complete listing of Linkage Products.

Manually Operated Valve

- Small, Self-Relieving Manual Switch

PART #	DESCRIPTION
90054088	All Ports 1/8" NPT



Pilot Valve

- Activated by applying pilot pressure
- Remote mounted valve suited for any chassis location
- Typically used on auxiliary axle applications or to rapidly exhaust air suspensions

PART #	DESCRIPTION
90554615	Port A - 1/4" NPT; Port B - 1/8"

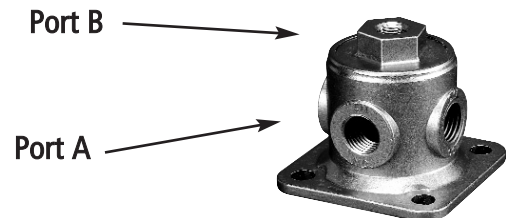

Pressure Protection Valves

Pressure Protection Valve

- E-coated zinc diecast body provides exceptional corrosion resistance
- Premium Nitrile diaphragm provides long life and reliability
- Durable design increases product life, reducing replacement costs
- Use in air suspensions, air seats and cab isolation systems



PART #	PORT SIZES	CLOSING PRESSURE	OPENING PRESSURE	FILTER
90554107	1/4" NPT	70 PSIG	75 PSIG Min.	Yes
90555397	1/4" NPT	80 PSI	85 PSI	No
90555398	1/4" NPT	90 PSI	90 PSI	No

Pressure Protection Valve with One-Way Check

- One-way check valve prevents reverse air flow
- Exceptional corrosion resistance



PART #	PORT SIZES	CLOSING PRESSURE	OPENING PRESSURE
90555409	1/4" NPT	65 PSI	70 PSIG
90555410	1/4" NPT	80 PSI	85 PSI
90555411	1/4" NPT	90 PSI	95 PSI

Double Diaphragm Spring Brakes

Gold Seal®

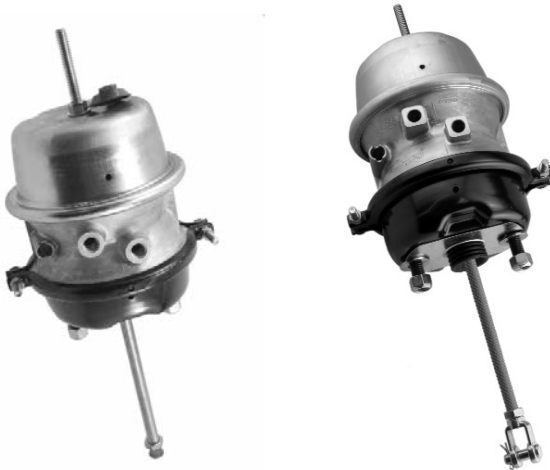

Standard Stroke Gold Seal®
Round ports; no special tags or embossed service instructions.

Long Stroke Gold Seal®
Square ports; trapezoidal shaped tag with stroke information; embossed or "cast-in" service instructions.

- Haldex Gold Seal® Spring Brake is standard equipment on all N.A. built medium and heavy duty trucks, tractors and most popular brand trailers.
- Haldex Gold Seal® is the first choice for standard equipment with many of the top national fleets in the US and Canada.
- Every Haldex Gold Seal® Spring Brake is backed with a four year, unlimited mileage warranty. See Haldex Warranty Policy L20221 for more details.

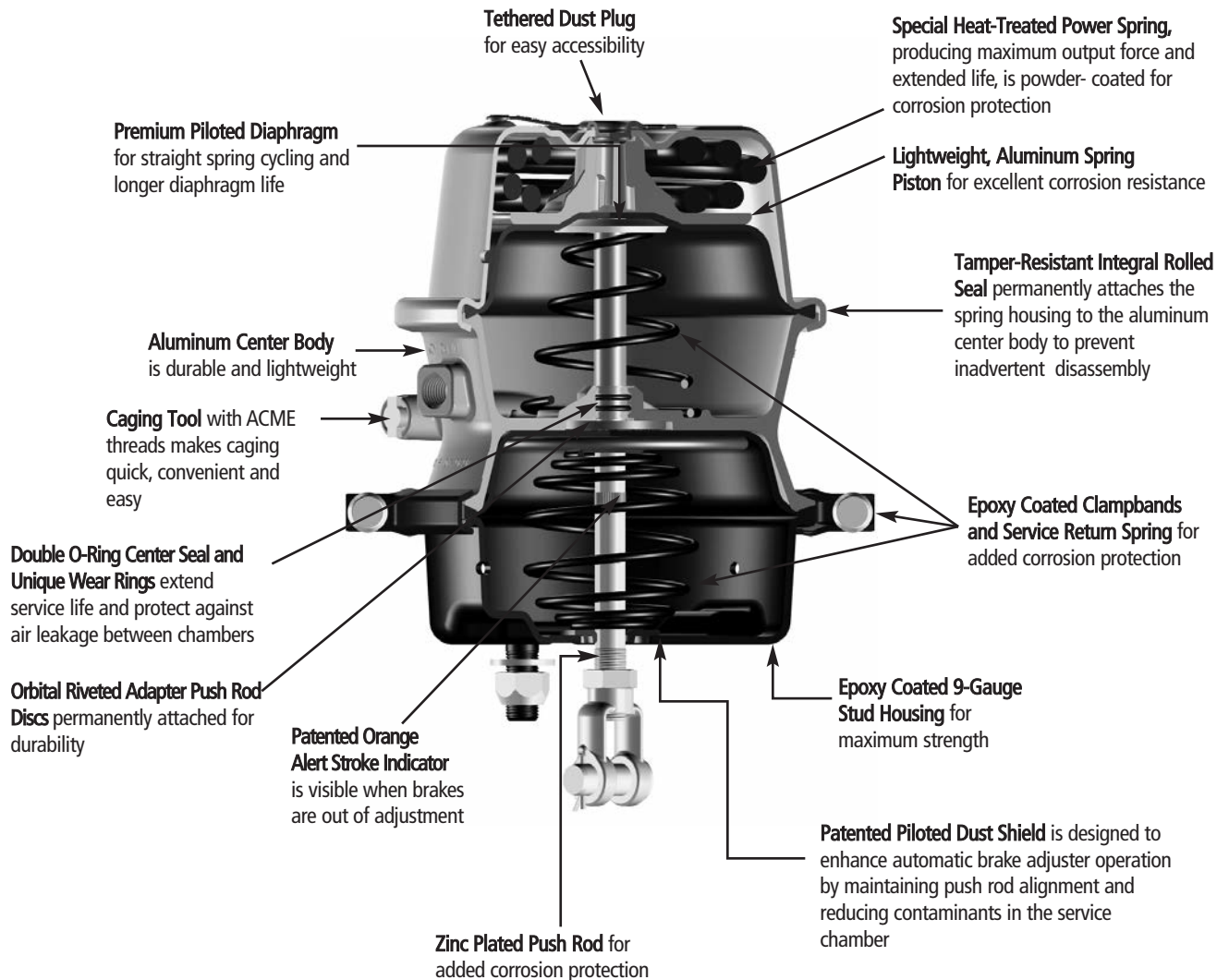

Double Diaphragm Spring Brakes

Life Seal®



Standard Stroke Life Seal®
Round ports; no special tags or embossed service instructions.



Long Stroke Life Seal®
Square ports; trapezoidal shaped tag with stroke information; embossed or "cast-in" service instructions.

- Haldex Life Seal® Spring Brake is the industry's first and only sealed double diaphragm spring brake.
- Haldex Life Seal® is the first choice for standard equipment with many of the top national fleets in the US and Canada.
- Every Haldex Life Seal® Spring Brake is backed with a six year, unlimited mileage warranty. See Haldex Warranty Policy L20221 for more details.

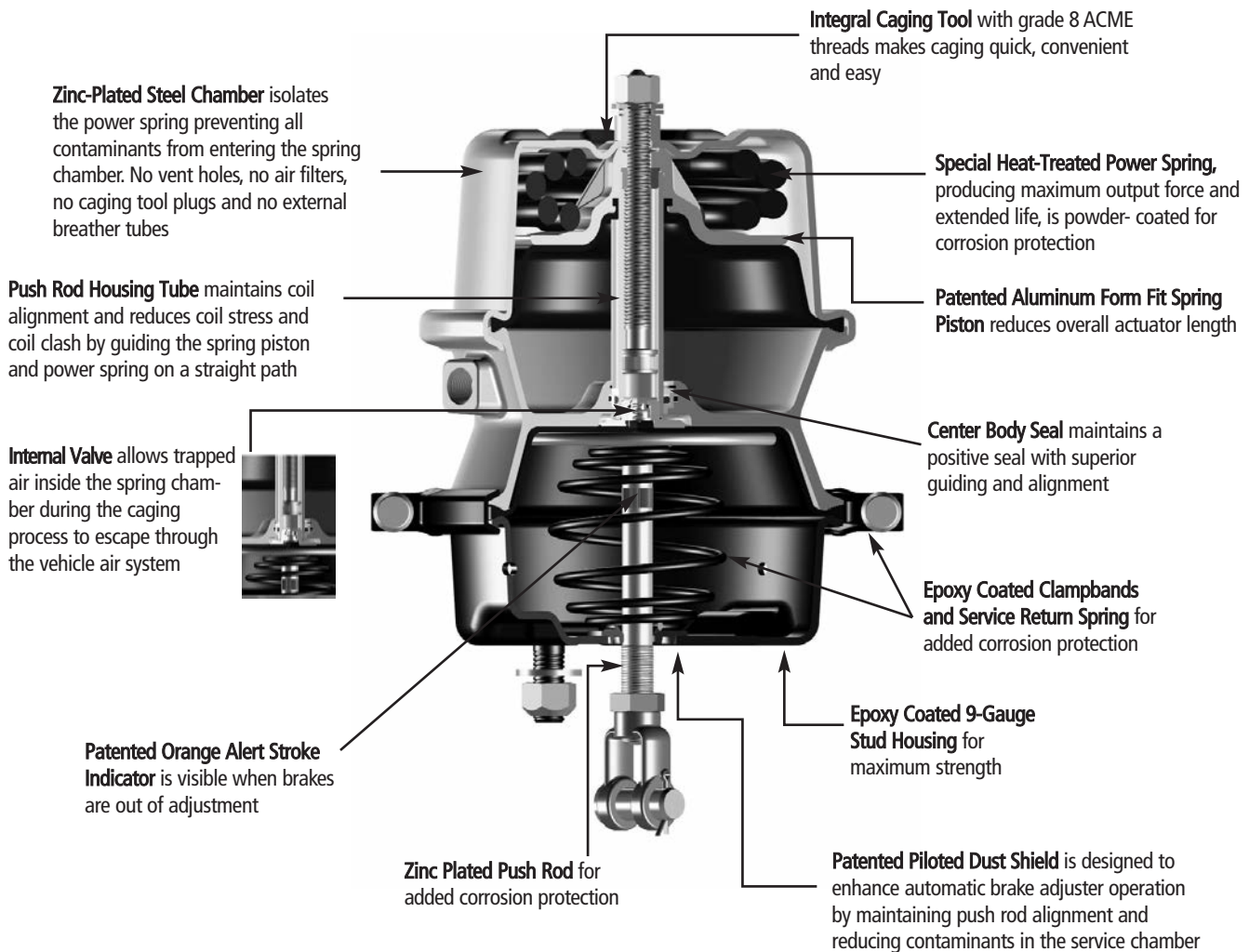

Double Diaphragm Spring Brakes

GOLD SEAL® PRODUCT DESCRIPTION	COMBO PART NO.	PIGGYBACK PART NO.	PIGGYBACK KIT PART NO.	AVAIL. STROKE	QTY. PER PKG.
2424	GC2424	GP2424		2.25"	2
2424 - Bulk Packed	GC2424P40			2.25"	40
2424 - Long Stroke	GC2424L	GP2424L		2.50"	2
2424 - Long Stroke/Bulk Packed	GC2424LP40	GP2424LP40		2.50"	40
2430	GC2430	GP2430		2.25"	2
2430 - Long Stroke	GC2430L	GP2430L		2.50"	2
2430 - Long Stroke/Bulk Packed	GC2430LP40			2.50"	40
3030	GC3030	GP3030	GP3030K (1 ea.)	2.50"	2
3030 - Bulk Packed	GC3030P40	GP3030P40	GP3030KP40	2.50"	40
3030 - Welded Clevis	GC3030CW			2.50"	2
3030 - Welded Clevis/Bulk Packed	GC3030CWP40			2.50"	40
3030 - Heavy Duty	GC3030HD			2.50"	1
3030 - 3/4" Diameter Pushrod	GC3030Q			2.50"	1
3030 - 14" Long Pushrod	GC3030R			2.50"	1
3030 - Long Stroke	GC3030L	GP3030L	GP3030LK (1 ea.)	3.00"	2
3030 - Long Stroke/Bulk Packed	GC3030LP40	GP3030LP40	GP3030LKP40	3.00"	40
3030 - Long Stroke/Welded Clevis	GC3030LCW			3.00"	1
3030 - Long Stroke/Welded Clevis/Bulk Packed	GC3030LCWP40			3.00"	40
3030 - Long Stroke/Heavy Duty	GC3030LHD			3.00"	1
3030 - Long Stroke/14" Long Pushrod	GC3030LR			3.00"	1
3036	GC3036	GP3036		2.50"	2
3036 - 3/4" Diameter Pushrod	GC3036Q			2.50"	1
3636	GC3636	GP3636 (2 ea.)		3.00"	1
3636 - Bulk Packed	GC3636P40			3.00"	40
3636 - Welded Clevis	GC3636CW			3.00"	1
3636 - 3/4" Diameter Pushrod	GC3636Q			3.00"	1
LIFE SEAL® PRODUCT DESCRIPTION	COMBO PART NO.	PIGGYBACK PART NO.	PIGGYBACK KIT PART NO.	AVAIL. STROKE	QTY. PER PKG.
3030	LC3030	LP3030	LP3030K	2.50"	1
3030 - Bulk Packed	LC3030P40	LP3030P40	LP3030KP40	2.50"	40
3030 - Welded Clevis	LC3030CW			2.50"	2
3030 - Welded Clevis/Bulk Packed	LC3030CWP40			2.50"	40
3030 - Heavy Duty	LC3030HD			2.50"	1
3030 - 14" Long Pushrod	LC3030R			2.50"	1
3030 - Long Stroke	LC3030L	LP3030L	LP3030LK	3.00"	1
3030 - Long Stroke/Bulk Packed	LC3030LP40	LP3030LP40		3.00"	40
3030 - Long Stroke/Welded Clevis	LC3030LCW			3.00"	2
3030 - Long Stroke/Welded Clevis/Bulk Packed	LC3030LCWP40			3.00"	40
3030 - Long Stroke/Heavy Duty	LC3030LHD			3.00"	1
3030 - Long Stroke/14" Long Pushrod	LC3030LR			3.00"	1

Service Chambers

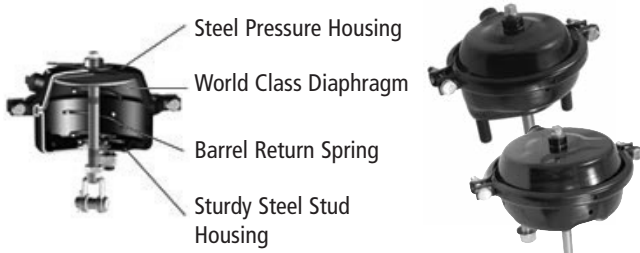

- Haldex Service Chambers are standard equipment on all N.A. built medium and heavy duty trucks and tractors
- Every Haldex Service Chamber is backed with a three year, 350,000 mile warranty (See Haldex Warranty Policy L20221 for more details)

SERVICE CHAMBER PRODUCT DESCRIPTION	SERVICE CHAMBER PART NO.	AVAIL. STROKE	QTY. PER PKG.
TYPE 9	SC09	1.75"	2
TYPE 12	SC12	1.75"	2
TYPE 16	SC16	2.25"	2
TYPE16 - Long Stroke	SC16L	2.50"	1
TYPE 20	SC20	2.25"	2
TYPE 20 - Bulk Packed	SC20P40	2.25"	40
TYPE 20 - Long Stroke	SC20L	2.50"	1
TYPE 20 - Long Stroke Welded Clevis	SC20LCW	2.50"	2
TYPE 24	SC24	2.25"	2
TYPE 24 - Bulk Packed	SC24P40	2.25"	40
TYPE 24 - Long Stroke	SC24L	2.50"	2
TYPE 24 - Ex. Long Stroke	SC24XL	3.00"	1
TYPE 24 - Ex Long Stroke Welded Clevis	SC24XLCW	3.00"	2
TYPE 24	SC24	2.25"	2
TYPE 24 - Bulk Packed	SC24P40	2.25"	40
TYPE 24 - Long Stroke	SC24L	2.50"	2
TYPE 24 - Ex. Long Stroke	SC24XL	3.00"	1
TYPE 24 - Ex Long Stroke Welded Clevis	SC24XLCW	3.00"	2
TYPE 30	SC30	2.50"	2
TYPE 30 - Bulk Packed	SC30P40	2.50"	40
TYPE 30 - Welded Clevis	SC30L	3.00"	1
TYPE 30 - Long Stroke	SC30LCW	3.00"	2
TYPE 30 - Long Stroke Welded Clevis	SC36	3.00"	2

Maxibrake® Spring Brakes



- Complete spring brake.
- All steel construction.
- Rugged/Corrosion resistant

MAXIBRAKE® PRODUCT DESCRIPTION	MAXIBRAKE® PART NO.	AVAIL. STROKE
2475 Universal Spring Brake	MA15775	2.25"
2475 REMAN	MA15775X	2.25"
3075 Universal Spring Brake	MA15777	2.62"
3075 REMAN	MA15777X	2.62"
3675 Universal Spring Brake	MA15779	3.00"
3675 REMAN	MA15779X	3.00"

Replacement Parts

PRODUCT DESCRIPTION	PART NO.	QTY. PER PKG.
Boot Assembly for 5/8" Pushrod	BA1	10
T-20 Clampband Kit	CB20	10
T-24 Clampband Kit	CB24	10
T-30 Clampband Kit	CB30	10
Clevis FD - 1/2" Pin	CF2	10
Clevis FD - 5/8" Pin	CF3	10
Clevis FD - 1/2" Pin - 3/4-16UNF	CF4	10
Clevis FD - 14MM Pin - M16x1.5	CF5	10
Clevis FD - 1/2" Stainless Pin	CF10	10
Clevis Pin - 1/2"	CP1	10
Clevis Pin - 5/8"	CP2	10
T-20 Diaphragm	DP20	10
T-20 LS Diaphragm	DP20L	10
T-24 and T-24 LS Diaphragm	DP24L	10
T-24 EX LS Diaphragm	DP24XL	10
T-30 Diaphragm	DP30	10
T-30 LS Diaphragm	DP30L	10
Dust Shield - 5/8" - Black	DS3	10
Dust Shield - 3/4" - Black	DS4	10
HW KIT - Lk Wsr & Nut - 5/8-11UNC	HW2	10
HW KIT - Wsr & Lk Nut - 5/8-11UNC	HW3	10
Jam Nut - 5/8-18UNF	HW5	10
Jam Nut - M16x1.5	HW6	10
CL Band Nut & Bolt - 3/8-24UNF	HW8	10
Elbow - Street 90° - 3/8-18NPTF	HW10	10
Pipe Plug - Square Head - 3/8-18NPTF	PP1	10
T-30 Service Push Rod - 5/8-18UNF	PR30	1
T-30 Service Push Rod - 3/4-14UNF	PR30S1	1
Spring - RT Gold & Life Seal 3030	RS5	1
Spring - RT All Other Except 3636 & RS5	RS6	1
Spring - RT 3636	RS7	1
Release Tool - All DDSB Except 3036/3636	RT1	10
Release Tool - 3036 & 3636	RT2	10
Release Tool - Remote Chamber	RT3	10
Release Tool Plug - All DDSB Exc	RTP1	10
3036/3636	RTP2	10
Release Stud Plug - Old Midland Style	RTP3	10
Release Tool Plug - 3036 & 3636		

Maxibrake® "H" Series



- For Durapark system spring brake only.
- All steel construction.
- Rugged/Corrosion resistant design.

MAXIBRAKE® PRODUCT DESCRIPTION	MAXIBRAKE® PART NO.	AVAIL. STROKE
H-Series Hydraulic Spring-Set Brake	MA15500	2.00"
H-Series Hydraulic; Remanufactured	MA15500X	2.00"
H-Series Hydraulic with Elbow Fitting	MA15502	2.00"
H-Series with Elbow Fitting; Reman.	MA15502X	2.00"
H-Series Air Spring-Set Parking Brake	MA15504	2.00"
H-Series Air Spring; Remanufactured	MA15504X	2.00"

7-Way Plugs & Receptacles

HEAVY DUTY DIE CAST PLUGS

- Durable zinc, diecast housing for rugged service
- Meets requirements of SAE J560
- Brass terminal pins for maximum current carrying ability
- Fully interchangeable with other SAE Type, 7-way plugs



PART #	DESCRIPTION
B202610	Replacement Insert
B205140	Spring Guard Only
BE23783	Trailer Plug Assembly Only
BE23784	Trailer Plug Assembly with Spring Guard

HEAVY DUTY DIE CAST RECEPTACLE

- Durable zinc, diecast housing for rugged service
- Meets requirements of SAE J560
- Brass terminal pins for maximum current carrying ability
- Fully interchangeable with other SAE Type, 7-way receptacles
- Wire insertion style



PART #	DESCRIPTION
B202611	Replacement Insert
B205010	Receptacle Boot
BE16797	Metal Door Lid Kit
BE23703	Receptacle Assembly - Split Pin

HEAVY DUTY POLY PLUG & RECEPTACLE



PART #	DESCRIPTION
BE16730	Plug Assembly w/Spring Guard
BE23707	Receptacle Assembly - Ring Terminal
BE23709	Receptacle Assembly - Bullet Terminal
BE23717	Receptacle Assembly - Wire Insert Style

DIE CAST AUXILIARY FOR SECONDARY CABLES

- Meets auxiliary requirements of SAE J560 (replaces ISO 3731)
- For use with secondary cable for auxiliary requirements
- Male ground pin on plug and female ground pin on receptacle prevent mixed connections



PART #	DESCRIPTION
B205010	Receptacle Boot
BE23712	Auxiliary Receptacle w/Die Cast Housing
BE23790	Auxiliary Plug w/Die Cast Housing and Spring Guard

TWO POLE PLUG & RECEPTACLE TAILGATE CONNECTORS

- One Positive - One Negative Pole
- 200 AMP Capacity
- Terminals Accept 4 Gauge Cable
- Receptable Lug - Stud Hole Size 1/4"



PART #	DESCRIPTION
B205010	Receptacle Boot
BE23201	Receptacle Assembly
BE23202	Plug Assembly w/Spring Guard

SINGLE POLE PLUG & RECEPTACLE TAILGATE CONNECTORS

- Plated Copper Grounding Lug.
- 300 Amp Capacity
- Plug Grounding Lug Accepts 4 Gauge Cable
- Receptable Lug - Stud Hole Size 5/16"



PART #	DESCRIPTION
B205010	Receptacle Boot
BE23101	Receptacle Assembly
BE23102	Plug Assembly w/Spring Guard

7-Way Plugs & Receptacles (cont'd)

CIRCUIT BREAKER STYLE RECEPTACLES WITHOUT HOUSING

- Receptacle only
- AMPS Ratings from 15 - 30 AMPS
- Mounting centers of 4 1/2" and an overall height of 2 1/2"
- Mounts in 4" opening
- Zinc plated split brass pins



PART #	DESCRIPTION
BE24000	Receptacle Without Housing - Less Breaker
BE24015	15 AMP Receptacle Without Housing
BE24020	20 AMP Receptacle Without Housing
BE24030	30 AMP Receptacle Without Housing
BQ24002	Cover Assembly

DIE CAST RECEPTACLE WITH LARGE MOUNTING PLATE

- Meets requirements of SAE J560
- Split pin, wire insertion
- Not equipped with circuit breakers
- Dedicated ground or ground connection is through mounting plate
- Gasket Included



PART #	DESCRIPTION
BE16797	Metal Replacement Lid Kit
BE23705	Receptacle With Large Mounting Plate

DIE CAST CIRCUIT BREAKER STYLE RECEPTACLE WITH POLY HOUSING

- AMPS Ratings from 15 - 30 AMPS
- Industry standard for trailer applications
- Zinc plated split brass pins
- Gaskets Included
- Housing Depth: 1 3/4"
- Overall Depth: 2 3/4"



PART #	DESCRIPTION
BE24115	15 AMP
BE24120	20 AMP
BE24130	30 AMP

6-Way Plug & Receptacle

- Quality zinc casting with Engineering Grade Composite (EGC) inserts



PART #	DESCRIPTION
BE23602	6-Way Receptacle
BE23603	6-Way Plug
BE23604	6-Way Plug with Spring Guard

4-Way Plug & Receptacle

- Quality zinc casting with Engineering Grade Composite (EGC) inserts



PART #	DESCRIPTION
BE23402	4-Way Receptacle
BE23403	4-Way Plug
BE23404	4-Way Plug with Spring Guard

7-Way Terminal Cleaner

- One end for plug
- One end for receptacle
- Stainless steel brushes
- One-year warranty



PART #
BE20400

Coiled Cables



DESCRIPTION	GAUGE WIRES	LEADS	12' PART #	15' PART #
Black Light Duty Powercoil w/Spring Guard - Non-ABS	1/12, 6/14	2@12"	BE27039	BE27019
Black Standard Duty Powercoil w/Spring Guard - Non-ABS	1/10, 6/12	2@12"	BE27029	BE27031
Green Ultra Heavy Duty ABS Powercoil w/Spring Guard	1/8, 2/10, 4/12	2@12"	BE27070	BE27071
Green Ultra Heavy Duty ABS Powercoil w/Spring Guard	1/8, 2/10, 4/12	1@12", 1@48"	n/a	BE27072
Green Ultra Heavy Duty ABS Powercoil w/Spring Guard	1/8, 2/10, 4/12	1@12", 1@72"	n/a	BE27073
Yellow ABS and Auxiliary Plug Powercoil w/Spring Guard	1/8, 2/10, 4/12	2@12"	n/a	BE27096

Electro-Pneumatic Switches

LOW AIR SWITCH

- Actuates at 66 PSI
- Single pole, two terminal
- Circuit position normally open
- 1/8-27 NPT Threads
- Available in 12V or 24V



PART # BE13241

TRACTOR SPRING BRAKE CIRCUIT LIGHT SWITCH

- Actuates at 55 PSI
- Single pole, two terminal
- Circuit position normally closed
- 1/8-27 NPT Threads
- Available in 12V or 24V



PART # BE13240

TRAILER EMERGENCY STOPLIGHT SWITCH

- Actuates at 55 PSI
- Single pole, double throw, three terminal
- Circuit position normally one open, one closed
- 1/8-27 NPT Threads
- Available in 12V or 24V



PART # BE13255

SERVICE CIRCUIT STOPLIGHT SWITCH

- Actuates at 3-5 PSI
- Single pole, two terminal
- Circuit position normally open
- 1/4-18 NPT Threads
- Available in 12V or 24V



PART # BE13250

Electric Trailer Brake Controllers

PRIMUS™ IQ BRAKE CONTROL

- Works proportionally in reverse
- No level adjustment necessary, adjusts to varying terrain as you drive
- Digital display shows voltage to trailer during braking
- Boost feature allows for customized braking
- Pre-assembled wire harness for simple hook-up and quick disconnect
- Diagnostic features incorporated in LED display
- Electric trailer brake control for up to three axles
- Limited Lifetime Warranty (some conditions apply)



PART # BE90155

VOYAGER BRAKE CONTROL

- Built to replace the Mark 12 (BE30212) and Mark 24 (BE30224)
- One-third the size of the Mark 12 and Mark 24
- Application for 2 or 4 wheel brakes



PART # BE30227

Single Conductor PVC

SINGLE CONDUCTOR PVC PRIMARY WIRE

- SAE J1128 TYPE GPT
- 300 Volts
- Poly-vinyl insulation with superior abrasive strength
- Highly resistant to acid, grease, oil and gasoline
- Compounded to incorporate moisture resistance and desirable aging characteristics
- Standard package 100' spool (Also available in mini-spools)



PART #	Color	PART #	Color
8 GAUGE			
BE28140	Black	BE28158	Black
BE28141	Red	BE28159	Blue
10 GAUGE			
BE28142	Black	BE28160	Green
BE28143	Blue	BE28161	Red
BE28145	Red	BE28162	Yellow
BE28147	White	BE28163	White
12 GAUGE			
BE28150	Black	BE28164	Brown
BE28151	Blue	16 GAUGE	
BE28152	Green	BE28166	Black
BE28153	Red	BE28167	Blue
BE28154	Yellow	BE28168	Green
BE28155	White	BE28169	Red
		BE28170	Yellow
		BE28171	White
		BE28172	Brown
		18 GAUGE	
		BE28174	Black

Primary Wire

JACKETED TWO CONDUCTOR

- Meets SAE J1128, Type GPT specifications
- Black, White Conductor Color
- Covered with gray PVC jacket
- Standard package 100' spool



PART #	DESCRIPTION
BE28820	16 Gauge
BE28821	14 Gauge
BE28822	12 Gauge

JACKETED THREE CONDUCTOR

- Meets SAE J1128, Type GPT specifications
- Black, Green, Red Conductor Color
- Covered with gray PVC jacket
- Standard package 100' spool



PART #	DESCRIPTION
BE28828	16 Gauge

Multi-Conductor Wire

BONDED THREE CONDUCTOR

- Meets SAE J1128, Type GPT specifications
- Brown, Yellow, Green Conductor Color
- Standard package 100' spool



PART #	DESCRIPTION
BE28825	14 Gauge

BONDED FOUR CONDUCTOR

- Meets SAE J1128, Type GPT specifications
- Brown, White, Green, Yellow Conductor Color
- Standard package 100' spool



PART #	DESCRIPTION
BE28826	16 Gauge
BE28827	14 Gauge

Battery Hardware

POST TYPE HEAVY DUTY UNIVERSAL BATTERY TERMINAL

- 1/0 Gauge 3-way Top Terminal
- 1 Set (One Neg./One Pos.)



PART #
BE20179

FLEET HEAVY DUTY UNIVERSAL BATTERY TERMINAL

- For temporary repair battery terminals.
- Universal, Clamp Type.
- 2/0 To 4/0 Gauge Cable.



PART #
BE20196

COPPER LUG - CLOSED TYPE BATTERY TERMINAL

PART #	DESCRIPTION
BE20140	4/0 Gauge; 1/2" Stud
BE20141	4/0 Gauge; 3/8" Stud
BE20142	3/0 Gauge; 1/2" Stud
BE20143	3/0 Gauge; 3/8" Stud
BE20144	2/0 Gauge; 3/8" Stud
BE20145	2/0 Gauge; 1/2" Stud
BE20146	1/0 Gauge; 1/2" Stud
BE20147	1/0 Gauge; 3/8" Stud



TOP POST - BATTERY TERMINAL

- Tin-plated Copper Alloy

PART #	DESCRIPTION
BE20222	1/0 Positive
BE20223	1/0 Negative
BE20224	2/0 Positive
BE20225	2/0 Negative

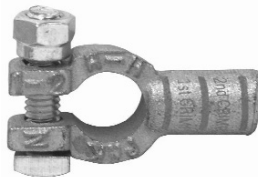

STUD NUTS - GROUP 31 BATTERIES

- Stainless Steel
- Universal polarity

PART #
BE20100



REPLACEMENT BOLT AND NUT FOR 5011 SERIES

PART #
BE31805



UNIVERSAL STYLE TERMINAL CONVERTER

PART #
BE31807



HEAVY DUTY TRUCK JUMPER CABLES AND GROUND STRAPS

PART #	DESCRIPTION	
BE20166	2/0 Gauge; 12"; Top Post to Top Post	
BE20172	4/0 Gauge; 12" Ground Strap	
BE31800	2/0 Gauge; 8"; Anti-Rotational Lugs; Top Stud to Top Stud	
BE31801	2/0 Gauge; 12"; Anti-Rotational Lugs; Top Stud to Top Stud	
BE4910	4/0 Gauge; 18" Ground Strap	

BOOSTER CABLE & ACCESSORIES

PART #	DESCRIPTION	
BE38001	20' Booster Cable	
BE38002	16' Booster Cable	
BE38004	500 Amp Clamp Set	

WELDING CABLE

- High grade soft annealed copper conductor
- High strand count for superior flexibility
- Jacketed with an oil-resistant black neoprene cover

PART #	DESCRIPTION
BE28810	4/0 Ga./25' Coil/.410" Nom. O.D. Minimum 418 Strands
BE28814	2/0 Ga./25' Coil/.634" Nom. O.D. Minimum 1273 Strands



Battery Hardware (cont'd)

BATTERY AND STARTER CABLES

- Conductors are made of high grade soft annealed copper
- High strand count for flexibility
- Meets the requirements of SAE J1127 - Type SGT
- Cable is jacketed with a specially formulated abrasion resistant PVC

DESCRIPTION	NOM. O.D.	25' COIL	100' COIL
4 Gauge/Red	0.346"	BE28809	BE28815
2 Gauge/Red	0.445"	BE28816	BE28817
1 Gauge/Red	0.482"	n/a	BE28800
1/0 Gauge/Black	0.514"	BE28808	BE28802
2/0 Gauge/Black	0.582"	BE28805	BE28804
3/0 Gauge/Black	0.662"	BE28807	BE28806
4/0 Gauge/Black	0.740"	BE28818	n/a

BLACK NON-ABS TRAILER CABLES

- Up to 10% more copper content than required by SAE J1128
- High conductor strand count for excellent flexibility
- Flexibility down to temperatures of 85 F (-65 C)
- Up to three times more abrasion resistant than competitive cables

DESCRIPTION	NOM. O.D.	100' COIL	500' COIL
Light Duty			
4/14; 4-Way	0.4206"	BE28414	BE28415
6/14; 6-Way	0.544"	BE28614	BE28615
6/14, 1/12; 7-Way*	0.554"	BE28714	BE28716
Standard Duty			
6/12, 1/10; 7-Way	0.581	BE28712	BE28715

* Also available in 250' Coil (P/N BE28727)

Switches

IGNITION KEY SWITCH

- Universal ignition starter switch
- 4 post connection
- Acc./off/on/start
- Waterproof o-ring sealed and has pick proof lock



PART # BE20097

AXLE SHIFT SWITCH

- Two speed
- Zinc diecasting
- Rubber cover

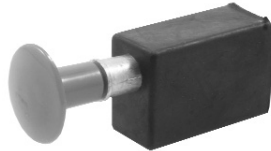

PART # BE20098

MASTER DISCONNECT SWITCHES

- Lever operated
- S.P.S.T. OFF-ON
- Two Stud Terminals

PART # BE20068



PART # BE20070

BUZZER

- Truck low air pressure and bus rear door warning signal
- 12V - Two Screw Terminals

PART # BE22638



PUSH-PULL SWITCH (EXTRA HEAVY DUTY)

- S.P.S.T ON-OFF
- 75 AMP, 6-28 Volts
- Stem: 5/8" Long; 15/32" Dia. Thread
- Chrome Plated, Diecast Knob



PART # BE20051

TOGGLE SWITCH

- U/L Listing: 20 AMP
- S.P.S.T. ON-OFF - 2 Screws

PART # BE20085



MOMENTARY PUSH SWITCH

- 60 AMP @ 12V; 40 AMP @ 24V
- Weather and Dust Proof Construction
- Silver Contacts
- Flush terminal screws
- Stem: 5/8" Long; 5/8" Dia. Thread

PART # BE20065



STARTER SOLENOID

- 85 AMPS @ 12 V Continuous Duty
- Insulated Base
- Operating Coil Connections

PART # BE68202



Haldex Air Treatment Products

DRYest® AIR DRYER

- Uses MTC+ 5-stage desiccant cartridge for superior drying and long service life
- Integrated turbo protection valve prevents loss of engine turbo
- Compact size makes installation easy, even as a drop-in dryer
- Built-in heater prevents freeze-ups
- Purge Tank Kit - **Part #47010001**



PART #	Heater Voltage	System Regen.	Internal Governor
DA35100	12 Volt	X	
DA35105	24 Volt	X	
DA35110*	12 Volt		
DA35115*	24 Volt		
DA35200	12 Volt	X	X
DA35205	24 Volt	X	X
DA35210*	12 Volt		X
DA35215*	24 Volt		X
DA35220*	None		X

*For use with external purge tank.

CONSEP® CONDENSER/SEPARATOR

- Condenses and separates oil, water and other contaminants in compressed air line, substantially increasing desiccant life
- Includes Haldex Automatic Drain Valve (ADV)
- Ideal for transit and heavy braking applications
- Installs between compressor and air dryer, or can be used as a stand alone unit
- Purges contaminants with each brake application



PART #	DESCRIPTION
41210026	12 Volt
41210029	24 Volt

MTC+ Multi-Treatment Cartridge

- Serpentine path makes MTC+ more efficient and extends dryer service life
- Different sized desiccant creates over 26% more surface area than competitor's single desiccant cartridge
- Service is quick and easy with 4-bolt slide in-and-out design

Stage 1: Aluminum Mesh for solid particles
 Stage 2: Large Desiccant for oil & water droplets
 Stage 3: Medium Desiccant for oil & water vapor
 Stage 4: Small Desiccant for water vapor
 Stage 5: Dust Filter for ultra-fine particles



Part #	DESCRIPTION
DQ6050	PURest MTC+ Kit
47178964	DRYest and ModulAir® MTC+ Kit

PURest® AIR DRYER

- Uses MTC+ 5-stage desiccant cartridge for superior drying and long service life
- Includes universal mounting bracket
- Integrated turbo protection valve prevents loss of engine turbo
- MTC+ Cartridge attaches with only 4 bolts, making for easy servicing and time savings



PART #	Heater Voltage
DA34100	12 Volt
DA34110	24 Volt
DA34160	12 Volt without Bracket
DA34200	12 Volt with "Econ" Valve

MODULAIR® AIR DRYER

- Large MTC+ 5-stage desiccant cartridge eliminates more contamination than single stage competitors (9.2 SCF drying capacity)
- Heat resistant brass turbo protection valve lasts longer than plastic composite valves
- Complete plug-n-play changeover from Bendix® AD-IS system
- Three-year warranty



PART #	Heater Voltage	System Regen.	Internal Governor
DA36100	12V & 24V	X	X
DA36200	12V & 24 V	Requires External Purge	X

EXTERNAL PURGE TANK KIT FOR MODULAIR®

PART #	DESCRIPTION
DQ6058	Kenworth T Series
DQ6060	Kenworth W 900 Series
DQ6061	Navistar Pro Series
DQ6063	Peterbilt
DQ6064	Kenworth (Behind the Cab)



ALCOHOL EVAPORATOR

- Easy to install
- Holds 40 oz. of Methyl Alcohol.
- Pressure protected
- The alcohol evaporator is an automatic vaporizing device for keeping air lines and air reservoirs free of ice.



PART # A72420

New and Remanufactured Bendix® Air Dryers & Cartridges



109477X



109685X



109991X



286934X



5004050X



65041X

AD-2

PART #	SUPPLY	DELIVERY	CONTROL	HEATER VOLTAGE
286934X	1/2"	1/2"	1/2"	12 Volt

NOTES

AD-2 Cartridge - **101900X**
AD-2 Fleet Svc. Kit - **101900MKX**

AD-4

PART #	SUPPLY	DELIVERY	CONTROL	HEATER VOLTAGE
65041X	1/2"	1/2"	1/4"	12 Volt

NOTES

AD-4 Cartridge - **104358X**
AD-4 Fleet Svc. Kit - **104358MKX**

AD-9

PART #	SUPPLY	DELIVERY	CONTROL	HEATER VOLTAGE
65224	1/2"	3/4"	1/4"	24 Volt
65225	1/2"	1/2"	1/4"	12 Volt
109685X	1/2"	1/2"	1/4"	12 Volt

NOTES

New AD-9 Dryer Soft Seat Purge
New AD-9 Air Dryer
AD-9 Cartridge - **107794X**
AD-9 Fleet Svc. Kit - **107794MKX**

AD-IP

PART #	SUPPLY	DELIVERY	CONTROL	HEATER VOLTAGE
109477RX	1/2"	1/2"	1/4"	12 Volt
109477X	1/2"	1/2"	1/4"	12 Volt

NOTES

CoreFree™ AD-IP Cartridge - **109493RX**
Reman AD-IP Cartridge - **109493X**
New AD-IP Cartridge - **65624K**

AD-IS

PART #	SUPPLY	DELIVERY	CONTROL	HEATER VOLTAGE
5004050X	1/4"	1/4"	1/4"	12 Volt

NOTES

New AD-IS Cartridge - **5008414K**

AD-SP

PART #	SUPPLY	DELIVERY	CONTROL	HEATER VOLTAGE
109991	1/2"	1/2"	1/4"	12 Volt
109991X	1/2"	1/2"	1/4"	12 Volt

NOTES

New AD-SP Air Dryer
New AD-SP Cartridge - **109994K**
AD-SP Purge Valve Kit - **109995K**

WABCO Air Dryers

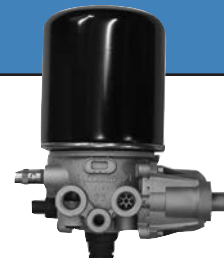

SS1200

PART #	SUPPLY	DELIVERY	CONTROL	HEATER VOLTAGE	NOTES
955205	1/2"-14 FPT	1/2"-14 FPT	1/4"-18 FPT	12 Volt	New SS1200 Compact Air Dryer SS1200 Cartridge - 95011K
955205X	1/2"-14 FPT	1/2"-14 FPT	1/4"-18 FPT	12 Volt	

Gladhands

CONVENTIONAL STYLE

- Economical heavy duty gladhand available in aluminum body/steel face or cast iron body
- Polarized and color coded in service configuration for easy identification of airlines
- Interchangeable with most competitive gladhands.
- Internal filter comes installed to protect airline from contamination



PART #	ALUMINUM/STEEL
11460	Universal; Seal 10028
11461	Emergency; Seal 10028
11462	Service; Seal 10028

Dual Lip Seal



Part # 10028

PART #	CAST IRON
A77770	Service; Seal 10029
A77771	Emergency; Seal 10029
A86300	Universal; Seal 10029

Compression Seal



Part # 10029

BRACKET MOUNT STYLE

- Bracket mount eliminates the need for additional mounting panels, lowering overall cost
- Heavy duty design projects 3.95" from mounting surface
- Polarized and color coded in service configuration for easy identification of airlines
- Includes **10028 Dual Lip Seal**, **10035 Filter** and loose 3/8" or 1/2" plug



PART #	DESCRIPTION
11440	Service; 3/8-18 Ports
11441	Emergency; 3/8-18 Ports
11444	Service; 1/2-14 Ports
11445	Emergency; 1/2-14 Ports

QRG (QUICK RELEASE GLADHAND)

- Unique patented design with built-in quick release valve
- Heavy Duty aluminum body and steel face
- Zinc yellow dichromate steel and chromate conversion coated aluminum
- Improves brake release timing by up to 67%
- Replaces service gladhands on the nose of the trailer



Nipple Mount



Bracket Mount

PART #	DESCRIPTION
11483	Nipple Mount
11484	40° Bracket Mount
RN58A	Repair Kit

Gladhand Grips

- Color-coded plastic handle
- Stainless steel screws
- Non-slip hex-shaped body is made from a high-impact UV-resistant polymer (shatter-proof)
- Inside edges are beveled which eliminates the hose-chafing sharp edge common in other designs



PART # 11405
(pair - one red/one blue)

Reservoirs

SADDLE-MOUNTED, SINGLE COMPARTMENT

- Long life internal and external corrosion protection
- Conform to SAE J10B specs
- Certified to 150 PSI working pressure.
- 1/4" drain port in bottom
- Two 3/8" charging ports, one each end.



PART #	DESCRIPTION
19810	1425 Cu. In. Volume; (1) 3/4" Valve Mounting Port; 8" Diameter; Mounting Center 32"
19820	2865 Cu. In. Volume; (2) 3/4" Valve Mounting Ports; 12" Diameter; Mounting Center 29 1/2"
19840	1490 Cu. In. Volume; (2) 3/4" Valve Mounting Ports; 9 1/2" Diameter; Mounting Center 27 1/2"

Coiled Air Hoses

- Coiled, 1/2" O.D., reinforced nylon tubing
- Excellent coil memory and durability
- Color coding (red-emergency / blue-service); Meets SAE J844 and DOT FMVSS 106
- 1/2" NPT each end
- Male pipe - brass fittings; heavy duty plated spring guards
- Designed for 150 PSI operating systems
- Resistant to attack by gasoline, diesel fuel, methyl-alcohol and zinc chloride
- Working temperature range is -40°F to +199°F
- Sets include one red and one blue coil



PART #	DESCRIPTION
11950	12'; 6" Lead
11952	15'; 12" Lead
11954	15'; (1) 48" Lead; (1) 12" Lead
11956	20'; (1) 48" Lead; (1) 12" Lead

Additional information is available in the Haldex Master Catalog (www.haldex.com).

Air Hoses

AIR HOSE ASSEMBLIES 3/8" I.D. x 3/4" O.D.

- Type B - permanent fittings
- Made in strict accordance with SAE J1402 and DOT 106 specifications

PART

1/4" Ends One Fixed One Swivel	3/8" Ends Both Ends Swivel	3/8" Ends One Fixed One Swivel
16014 - 14"	16418 - 18"	16618 - 18"
16016 - 16"	16420 - 20"	16620 - 20"
16018 - 18"	16424 - 24"	16622 - 22"
16020 - 20"	16428 - 28"	16624 - 24"
16022 - 22"	16430 - 30"	16626 - 26"
16024 - 24"	16436 - 36"	16628 - 28"
16026 - 26"	16442 - 42"	16630 - 30"
16028 - 28"	16448 - 48"	16632 - 32"
16030 - 30"	16460 - 60"	16634 - 34"
16032 - 32"		16636 - 36"
16034 - 34"		16438 - 38"
16036 - 36"		16640 - 40"
16038 - 38"		16642 - 42"
16040 - 40"		16644 - 44"
16042 - 42"		16646 - 46"
16044 - 44"		16648 - 48"
16046 - 46"		16654 - 54"
16048 - 48"		16660 - 60"
16054 - 54"		16672 - 72"
16060 - 60"		
16072 - 72"		

AIR HOSE ASSEMBLIES 1/2" I.D. x 7/8" O.D.

- Type B - permanent fittings
- Made in strict accordance with SAE J1402 and DOT 106 specifications
- Hose rack - **Part # 200997B**
- Assortment with hose rack - **Part #DQ16002**

PART

3/8" Ends One Fixed One Swivel	3/8" Ends Both Ends Swivel	One 1/2" Fixed End One 3/8" Swivel End
16316 - 16"	16718 - 18"	16820 - 20"
16318 - 18"	16720 - 20"	16824 - 24"
16320 - 20"	16722 - 22"	16830 - 30"
16322 - 22"	16724 - 24"	16836 - 36"
16324 - 24"	16726 - 26"	16848 - 48"
16326 - 26"	16728 - 28"	16860 - 60"
16328 - 28"	16730 - 30"	16872 - 72"
16330 - 30"	16732 - 32"	
16332 - 32"	16734 - 34"	
16334 - 34"	16736 - 36"	
16336 - 36"	16738 - 38"	
16338 - 38"	16740 - 40"	
16340 - 40"	16748 - 48"	
16342 - 42"	16756 - 56"	
16344 - 44"	16772 - 72"	
16346 - 46"		
16348 - 48"		
16352 - 52"		
16354 - 54"		
16356 - 56"		
16360 - 60"		

3-IN-1 AIR POWER LINE

- Power Line is fully ABS compatible.
- Improved kink resistance versus coiled hoses, particularly in cold weather
- Air lines have factory crimped swivel fittings at tractor end for quick installation
- Stainless steel hanger bracket mounting assembly included for easy suspension
- Red and blue hose grips for easy identification and gladhand connection

PART

BE27107	- 10'
BE27127	- 12'
BE27157	- 15'
BE27207	- 20'
11615	- Stainless Steel Hanger



Service Air Line - SAE J1402 Rubber
 Emergency Air Line - SAE J1402 Rubber
 ABS Power Line (Green) - Flexible in Cold Weather
 Enclosed in Heavy Duty, Bevelled Edge Spiral Wrap

Air Hose Fittings and Accessories

HOSE END FITTINGS - USE WITH BULK 3/8" I.D. HOSE

PART

- 11906 (A) Nut (for fitting without spring)
- 11907 (B) Body; 1/4-NPT
- 11908 (B) Body; 3/8-NPT
- 11909 (B) Body; 1/2-NPT
- 11910 (C) Nut (for fitting with spring)
- 11911 (D) Spring
- 11912 (E) Ferrule
- 11914 (F) Union Fitting Body

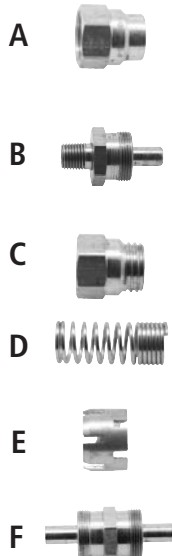

RENEWABLE HOSE END FITTING ASSEMBLIES - USE WITH 3/8" I.D. HOSE

PART

- 11900 (A) 1/4-NPT Male End with Spring
- 11901 (A) 3/8-NPT Male End with Spring
- 11902 (A) 1/2-NPT Male End with Spring
- 11903 (B) 1/4-NPT Male End without Spring
- 11904 (B) 3/8-NPT Male End without Spring
- 11905 (B) 1/2-NPT Male End without Spring
- 11913 (C) Hose Union



AIR LINE FILTER ASSEMBLIES

- Removable and replaceable filter element
- Can be used in both emergency/service lines

PART

- 11480 Complete Assembly
- N12971B Replacement Filter
- RN13A Repair Kit



Accessories

FLEXASTIKS

- OE hose support pogo sticks
- Available with spring only, or with various mounting items



ZINC DICHROMATE

PART #	LENGTH	HOSE CLAMP	SUPPORT BRACKET	HOSE RING
11500	41"	11547	-	-
11501	41"	11547	11403	-
11502	41"	-	-	11611
11503	41"	-	11403	11611
11504	51"	11547	-	-
11505	51"	11547	11403	-
11506	51"	-	-	11611
11507	51"	-	11403	11611
11508	41"	-	-	-
11509	51"	-	-	-

CHROME

PART #	LENGTH	HOSE CLAMP	SUPPORT BRACKET	HOSE RING
11510	41"	11547	-	-
11511	41"	11547	11403	-
11512	41"	-	-	11611

SUPPORT SPRINGS

ZINC DICHROMATE FINISH

PART #	DESCRIPTION
11600	25 1/2"; 1 1/8" Coil O.D.
11601	13"; 3/4" Coil O.D.
11602	13"; 1" Coil O.D.
11603	16"; 1 1/16" Coil O.D.



HOSE CLAMPS

PART # 11540

2-Hole; 3/8" I.D.



PART #11541

2-Hole; 3/8" I.D.; Rubberized For Coiled Airlines



PART # 11542

3-Hole; 3/8" I.D.



PART #11543

3-Hole; 3/8" I.D.



PART # 11544

3-Hole; 3/8" I.D.; Rubberized For Coiled Airlines



PART #11545

3-Hole; 3/8" & 1/2" I.D.



HOSE SEPARATORS

- Molded White (EGC) Engineering Grade Composite
- Snap Connect



PART #	DESCRIPTION
11548	For 3/8" I.D. Hose
11549	For 1/2" I.D. Hose

HOSE COUPLER WITH CHAIN

- Zinc & Yellow Dichromate Body



PART # 11401 (w/vent hole) PART # 11403
PART # 11402 (w/o vent hole)

HOSE SUPPORT BRACKET

- For Current Design Flexastiks



PART # 11546

3-Hole; 3/8" & 1/2" I.D.



PART #11547

3-Hole; 3/8" & 1/2" I.D.



PART # 11611

Hose Ring Assembly; 3/8" & 1/2" I.D.



PART # 11615

Stainless Steel Hanger, Use with Use with ABS Power Lines



Manual Brake Adjusters

MANUAL BRAKE ADJUSTERS - STRAIGHT ARM

- Forged steel
- 26,000 in. lbs.
- Bi-directional design
- Clevis Bushing Part #45210129



PART #	ARM LENGTH	SPLINE
KN44041	6.0	1 5/8" - 37
KN44051	5.0, 6.0	1 1/2" - 28
KN44061	5.5, 6.5	1 1/2" - 28
KN47001	5.0, 6.0, 7.0	1 1/2" - 10
KN47002	4.5, 5.5	1 1/2" - 10
KN47011	5.5, 6.5	1 1/2" - 10
KN47081	5.0, 6.0	1 1/2" - 10
KN48001	5.0, 6.0	1 1/4" - 10
KN48031	4.5, 5.5	1 1/4" - 10
KN52040	4.0, 5.0	1 1/4" - 40
KN52050	5.5	1 1/2" - 48
KN52060	4.0, 5.0	1 1/2" - 48
KN55001	5.5	1 1/4" - 24

MANUAL BRAKE ADJUSTERS - 5/8" OFFSET ARM

- Ductile iron
- 20,000 in. lbs.
- Right and left hand
- Clevis Bushing Part #45210129

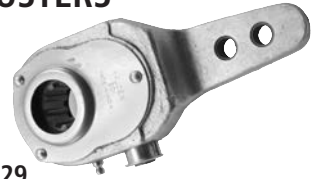

PART #	ARM LENGTH	SPLINE
KN49000 RH	4.5, 5.5	1 1/4" - 10
KN49010 LH	4.5, 5.5	1 1/4" - 10
KN49020 RH	4.0, 5.0, 6.0	1 1/4" - 10
KN49030 LH	4.0, 5.0, 6.0	1 1/4" - 10
KN50000 RH	4.5, 5.5	1 1/2" - 10
KN50010 LH	4.5, 5.5	1 1/2" - 10
KN50060 RH	4.0, 5.0, 6.0	1 1/2" - 10
KN50070 LH	4.0, 5.0, 6.0	1 1/2" - 10
KN53000 RH	5.0, 6.0	1 1/2" - 28
KN53010 LH	5.0, 6.0	1 1/2" - 28
KN53020 RH	5.5	1 1/2" - 28
KN53030 LH	5.5	1 1/2" - 28
KN54000 RH	5.5	1 1/4" - 24
KN54010 LH	5.5	1 1/4" - 24

Automatic Brake Adjuster Quick-Reference Guide

Application	Spline	Arm Length	ABA Kit Part #	Anchor Bracket Style	S-ABA Kit Part #
Standard Application Tractor	1 1/2" - 28	6.0	40010140	Strap	40020234
	1 1/2" - 28	5.5	40010141	Strap	40020231
	1 1/2" - 10	5.0, 6.0	40010142	Strap	40020233
	1 1/2" - 10	5.5	40010143	Strap	40020228
Mack Truck Applications (with 3" and longer camshaft tubes)	1 1/2" - 28	6.0	40010144	Clamp	40020243
	1 1/2" - 28	6.0	40010067*	Spider Mounted	n/a
	1 1/2" - 28	5.5	40010146	Clamp	n/a
	1 1/2" - 10	6.0	40010145	Clamp	40020244
Meritor Air Disc Brake	1 1/2" - 28	5.5	40010402	Strap	n/a
	1 1/2" - 10	6.0	40010637	Strap	n/a
Kenworth with 8 Bag Air Ride (to avoid interference with air bag supports)	1 1/2" - 28	5.5	40010156	Strap	n/a
	1 1/2" - 10	5.5	40010155	Strap	40020238
Trailer	1 1/2" - 28	6.0	40010212	Plate & Flat Stud	40020212
	1 1/2" - 28	5.5	40010211	Plate & Flat Stud	40020211
	1 1/2" - 10	6.0	40010216	Plate & Flat Stud	40020216
	1 1/2" - 10	5.5	40010215	Plate & Flat Stud	40020215
	1 5/8" - 37	5.5	40010213	Plate & Flat Stud	40020213
	1 5/8" - 37	6.0	40010214	Plate & Flat Stud	40020214

*For short camshaft tube Mack, 2" or less.

Haldex AA1 Automatic Brake Adjuster

- Installation indicator confirms correct installation
- Chrom-moly gears and a buttress tooth configuration on the gears reduce stress and prolong service life
- Compatible with all major brand clevises
- Heat treated adjuster housing to reduces internal wear and provides longer service life
- 1,000,000 Mile, 6 year on-highway warranty



PART #	ARM LENGTH	SPLINE	ANCHOR BRACKET STYLE	PART #	ARM LENGTH	SPLINE	ANCHOR BRACKET STYLE
40010067*	6.0	1 1/2" - 28	Spider Mounted	40010156	5.5	1 1/2" - 28	Strap
40010140	5.0, 6.0	1 1/2" - 28	Strap	40010211	5.5	1 1/2" - 28	Plate & Flat Stud
40010141	5.5, 6.5	1 1/2" - 28	Strap	40010212	6.0	1 1/2" - 28	Plate & Flat Stud
40010142	5.0, 6.0	1 1/2" - 10	Strap	40010213	5.5	1 5/8" - 37	Plate & Flat Stud
40010143	5.5, 6.5	1 1/2" - 10	Strap	40010214	6.0	1 5/8" - 37	Plate & Flat Stud
40010144**	6.0	1 1/2" - 28	Clamp	40010215	5.5	1 1/2" - 10	Plate & Flat Stud
40010145	6.0	1 1/2" - 10	Clamp	40010216	6.0	1 1/2" - 10	Plate & Flat Stud
40010146	5.5, 6.5	1 1/2" - 28	Clamp	40010402	5.5	1 1/2" - 28	Strap
40010155	5.5	1 1/2" - 10	Strap	40010637	6.0	1 1/2" - 10	Strap

* For short camshaft tube Mack, 2" or less.

** For Mack Truck with 3" and longer camshaft.

Haldex S-ABA Automatic Brake Adjuster

- High alloy steel gears
- Rolled wormshaft
- Heat-treated housing
- Centralized clutch

PART #	ARM LENGTH	SPLINE	ANCHOR BRACKET STYLE	BRACKET PART #
40020211	5.5	1 1/2" - 28	Plate & Flat Stud	42710563
40020212	6.0	1 1/2" - 28	Plate & Flat Stud	42710563
40020213	5.5	1 5/8" - 37	Plate & Flat Stud	42710563
40020214	6.0	1 5/8" - 37	Plate & Flat Stud	42710563
40020215	5.5	1 1/2" - 10	Plate & Flat Stud	42710563
40020216	6.0	1 1/2" - 10	Plate & Flat Stud	42710563
40020228	5.5	1 1/2" - 10	Strap	42710543
40020231	5.5	1 1/2" - 28	Strap	42710553
40020233	5.0, 6.0	1 1/2" - 10	Strap	42710553
40020234	6.0	1 1/2" - 28	Strap	42710553
40020238	5.5	1 1/2" - 10	Strap	42710554
40020243	6.0	1 1/2" - 28	Clamp	42710566
40020244	6.0	1 1/2" - 10	Clamp	42710566

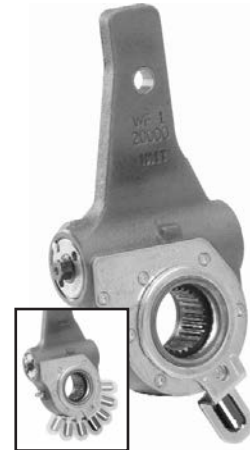

S-ABA allows the control arm to be set at any angle from minus 16 to 124 degrees.

CSI Automatic Brake Adjusters

- Includes collar lock clevis (except offset)
- Un-handed design
- Drilled for camshaft lubrication
- Installation gauge included
- Long stroke compatible
- Double sealed for long life
- Factory lubricated

HALDEX PART #	FLEET LINE PART #	ARM LENGTH	SPLINE	COLLAR LOCK KIT
CS56043	AS1143	5.5	1.625" - 37	CQ36545
CS56044	AS1144	6.0	1.625" - 37	CQ36545
CS56045	AS1145	6.5	1.625" - 37	CQ36545
CS56046	AS1146	5.5	1 1/2" - 10	CQ36545
CS56047	AS1147	6.0	1 1/2" - 10	CQ36545
CS56048	AS1148	6.5	1 1/2" - 10	CQ36545
CS56049	AS1149	5.5	1 1/2" - 28	CQ36545
CS56050	AS1150	6.0	1 1/2" - 28	CQ36545



Consult the Haldex Master Catalog (www.haldex.com) for a complete listing of Brake Adjusters offered.

New and Remanufactured Water Pumps

CATERPILLAR ENGINE - 3208

• Bolt On Pulley

PART #	DESCRIPTION
RW1162	New
RW1162RX	Reman CoreFree™
RW1162X	Reman



CUMMINS IDLER - SMALL CAM

• 2-Belt Pulley

PART #	DESCRIPTION
RW1175	New
RW1175RX	Reman CoreFree™
RW1175X	Reman



CATERPILLAR ENGINE 3406 B/C

• Flat Gear

PART #	DESCRIPTION
RW1194	New
RW1194BPK	Back Plate Kit
RW1194PRX	Premium Reman CoreFree™
RW1194PX	Premium Reman



CUMMINS KIT - BIG CAM

PART #	DESCRIPTION
RW3000	New Water Pump/Idler Kit



CUMMINS ENGINE - BIG CAM IV

• Multi-Groove Pulley

PART #	DESCRIPTION
RW1172	New
RW1172RX	Reman CoreFree™
RW1172X	Reman



DDC - 60 SERIES

• Gear Driven; Premium Seal

PART #	DESCRIPTION
RW4122PLK	Plastic Backing Plate Kit
RW4122PRX	Premium Reman CoreFree™
RW4122PX	Premium Reman
RW4122RX	Reman CoreFree™
RW4122STK	Steel Backing Plate Kit
RW4122X	Reman



CUMMINS ENGINE - BIG CAM III

• Multi-Groove Pulley

PART #	DESCRIPTION
RW1170	New
RW1170RX	Reman CoreFree™
RW1170X	Reman



MACK ENGINE - MAXIDYNE

• 1.57" Long Shaft; No Pulley

PART #	DESCRIPTION
RW2001	New
RW2001X	Reman



CUMMINS ENGINE - SMALL CAM

• 2-Groove Pulley

PART #	DESCRIPTION
RW1171	New
RW1171RX	Reman CoreFree™
RW1171X	Reman



MACK ENGINE - ECONODYNE

• Charged Air; No Pulley

PART #	DESCRIPTION
RW2002	New
RW2002X	Reman



CUMMINS IDLER - BIG CAM

• Multi-Groove Pulley

PART #	DESCRIPTION
RW1173	New
RW1173RX	Reman CoreFree™
RW1173X	Reman



NAVISTAR ENGINE - DT466

• Belt driven

PART #	DESCRIPTION
RW1190	New
RW1190RX	Reman CoreFree™
RW1190X	Reman



ABS (Anti-Lock Braking System) Valves

2S/1M ABS RELAY VALVE KIT

Dollies and Single Axle Applications

PART # AQ960505

- ABS Relay Valve (2 Port, 12V, 1/2" Res., 3/8" Cont., 3/8" Del.)
- ECU Design PLC Select
- 6.0m Power Cord Extensions
- 2.5m 90° Sensors and Clips



2S/1M FFABS VALVE KITS

Multi-Axle Applications

- New trailer placement; non-steer axles
- Pre-installed reservoir nipple nut feature assures easy serviceability
- ECU and ABS Valve are designed to be serviced separately
- 4-Port Valve: 3/4" Nipple; 12V; 3/8" Ports; Spring Brake Priority



AQ960208 Shown

PART #	DESCRIPTION
AQ960208	20x12m Power Cord; 2.5m Full 90° Sensors and Clips
AQ960802	20x12m Power Cord; ABS Light Kit; 2.5m Sensor Ext.
AQ961402	2.5m Sensor Extensions
AQ961404	6.0m Power Cord Extension; 2.5m Sensor Extensions

4S/2M ABS RELAY OR FFABS VALVE KIT

New Trailer Build Solutions

- ECU and ABS Valve are designed to be serviced separately
- ECU Design - PLC Select 2M



AQ963005 Shown

PART #	DESCRIPTION
AQ963004	2-Port ABS Relay Valve; Tandem Axles; 1/2" Res. Port; 12V; 3/8" Cont.; 3/8" Del.; 6m Power Cord Ext.; 1.5m and 2.5m Sensor Extensions
AQ963005	6-Port ABS Relay Valve; Tri-Axles; 1/2" Res. Port; 12V; 3/8" Cont.; 3/8" Del.; 6m Power Cord Extension; 2m and 3m Sensor Extension
AQ963013	4-Port FFABS Valve; Tri-Axles; 3/4" Nipple; 12V; 3/8" Ports; Spring Brake Priority
AQ963014	2-Port FFABS Valve; Tandem Axles; 3/4" Nipple; 12V; 3/8" Ports; Spring Brake Priority

2S/1M RELAY VALVE KITS

Multi-Axle Applications

- Competitive replacement
- For non-steer axles
- Cost effective solution for competitive system change-out
- ECU and ABS Valve designed to be serviced separately



AQ960503 Shown

6-Port ABS Relay Valve: 1/2" Res. Port, 12V, 3/8" Control, 3/8" Delivery

2S/1M 6-Port Multi-Axle Kit

PART #	DESCRIPTION
AQ960503	6.0m Power Cord Extension; 3.0m Sensor Extensions

2S/1M 6-Port Tandem Spring Suspension Kit

PART #	DESCRIPTION
AQ960510	6.0m Power Cord Extension; 2.0m Sensor Extensions

4-Port ABS Relay Valve: 1/2" Res. Port, 12V, 3/8" Control, 3/8" Delivery, Special Mounting Bracket

2S/1M 4-Port Tandem Air Ride Suspension Kit

PART #	DESCRIPTION
AQ960514	6.0m Power Cord Extension; 2.5m Sensors and Clips; All Miscellaneous Hardware Required

2S/1M 4-Port Multi-Axle Kit

PART #	DESCRIPTION
AQ960515	6.0m Power Cord Extension; 2.5m Sensors and Clips

ABS (Anti-Lock Braking System) Valves

4S/2M ABS KITS

Primarily Competitive Change-Out

- Cost effective solution for competitive system change-out
- ECU and ABS Valve are designed to be serviced separately



PART #	DESCRIPTION
AQ963002	4-Port Valve; Dual Nipple 1/2" and 3/4"; 12V; 3/8" Ports; Spring Brake Priority; 2 Port Relay Valve and Associated Cables and Accessories Included.
AQ963011	2-Port Valve; Dual Nipple 1/2" and 3/4"; 12V; 3/8" Ports; Spring Brake Priority; 2 Port Relay Valve and Associated Cables and Accessories Included.

ABS RELAY VALVE

2-Port and 6-Port Delive



AL364040
Shown

2-Port Delivery

Single Axle Applications (2S/1M or 4S/2M)

PART #	DESCRIPTION - 2-Port Delivery
AL364040	1/2" Reservoir Mount; 12V; 3/8" Ports
AL364045	1/2" Frame Mount; 12V; 3/8" Ports
AL364080	1/2" Reservoir Mount; 24V; 3/8" Ports

6-Port Delivery

Multiple Axle Applications (2S/1M);

Three or More Axles (4S/2M)

PART #	DESCRIPTION - 6-Port Delivery
AL364041	1/2" Reservoir Mount; 12V; 3/8" Ports
AL364046	1/2" Frame Mount; 12V; 3/8" Ports

FFABS

2-Port and 4-Port Delivery



AL430614
Shown

2-Port Delivery Single Axle Applications (2S/1M or 4S/2M)

PART #	DESCRIPTION
AL430644	1/2" & 3/4" Nipple; 12V; 3/8" Ports Service Brake Priority
AL430664	1/2" & 3/4" Nipple; 12V; 3/8" Ports Spring Brake Priority
AL430670	1/2" & 3/4" Nipple; 12V; 3/8" Ports Spring Brake Priority (4-SB Port)
AL430672	1/2" & 3/4" Nipple; 12V; 3/8" Ports Service Brake Priority (4-SB Port)

4-Port Delivery

Multiple Axle Applications (2S/1M);

Three or More Axles (4S/2M)

PART #	DESCRIPTION
AL430614	1/2" & 3/4" Nipple; 12V; 3/8" Ports Service Brake Priority
AL430620	1/2" Nipple; 24V; 3/8" Ports Service Brake Priority
AL430624	1/2" & 3/4" Nipple; 12V; 3/8" Ports Spring Brake Priority
AL430666	1/2" & 3/4" Nipple; 12V; 3/8" Ports Spring Brake Priority (4-SB Port)
AL430668	1/2" & 3/4" Nipple; 12V; 3/8" Ports Service Brake Priority (4-SB Port)

Meritor WABCO Style Remanufactured ABS Truck Valves



Part#	Description	Truck/Tractor/Bus Application
4725001000X	Remanufactured Rear Axle Valve Pack	Tandem Drive Axle
4721950520X	Remanufactured Modulator Valve	In Line Style
4721950950X	Remanufactured Modulator Valve	In Line Style
9730110210X	Remanufactured Service Brake Relay Valve for Valve Pack	Rear Axle ABS
9735001040X	Remanufactured Quick Release Valve for Valve Pack	Front Axle ABS

Trailer Roll Stability (TRS) Applications

- 4S/2M ABS with Roll Stability Support
- ECU and Dual Modulator Valve Serviced Separately
- Integral Lateral Accelerometer to monitor Roll Stability
- Integral Control Line Filter
- Made of EGC material for light weight, durability and environmental protection
- Works with standard ABS Wheel Speed Sensors



AL833000 Valve
and AL919337 ECU
Shown

Part#	Description	Application
AL364429	TRS Info Center	July 2005 to Present Production, 12V, American Standard Units for TRS
AL833000	TRS Dual Modulator Valve	NPT Ports: Res 1/2"; Control 3/8"; Air Bag 3/8"; 6-Delivery 3/8"
AL919337	TRS ECU	12V with Three Auxiliary Ports
AQ15853	TRS PC Diagnostic Kit	12V; CD; Interface Cabling (PC not included)
AQ968302	TRS Premium Retrofit Kit	12V, TRS Components for Retrofit of existing 4S/2M ABS Installations
AQ968303	TRS Service Kit	Service Components for GEN 1 ECU (AL919329) and PLC Power Adapter (AL95691)
AQ968304	TRS Replacement Kit	Heil Special; TRS Components for Retrofit of existing 4S/2M ABS Installations

Electronic Control Unit (ECU)

PLC/Plus 19 Pin

- SLH-A7 ECU
Multi-Axle (Non-Steer Axles)
- SLH-A8 ECU
Single and Dolly Axles



PART #	DESCRIPTION
AL919311	PLC ECU - SLH-A7 - 19 Pin - 2 Keys-Diagonal
AL919312	PLC ECU - SLH-A8 - 19 Pin - 2 Keys-Across

ECU Upgrade Kits

- Wheel speed sensor and Trailer power connects directly to ECU (no intermediate cables required)
- Single fastener design assures easy serviceability
- Potted ECU enclosure provides excellent protection from the environment



AQ964111
Shown

PART #	DESCRIPTION
AQ960502	2S/1M A8 ECU Upgrade Kit; PLC Select ECU
AQ964110	2S/1M A7 ECU Upgrade Kit; PLC Select ECU
AQ964111	4S/2M ECU Upgrade Kit; 2M PLC Select ECU

PLC Select 1M and 2M

- Wheel speed sensor and Trailer power connects directly to ECU (no intermediate cables required)
- Single fastener design assures easy serviceability
- Potted ECU enclosure provides excellent protection from the environment



AQ919338
Shown

PLC Select 1M supports all 2S/1M applications

PART #	DESCRIPTION
AL919336	PLC Select PLUS ECU - DIN 12V - SLH-A7 - Multi-Axle
AL919338	PLC Select 1M ECU - DIN 12V - SLH-A7 - Multi-Axle (Non-Steer Axles)
AL919339	PLC Select 1M ECU - DIN 12V - SLH-A8 - Dollies/Single Axle
AL919340	PLC Select 1M ECU - DIN 12V - SLH-A7 - Multi-Axle (Non-Steer Axles)
AL919341	PLC Select 1M ECU - DIN 12V - SLH-A8 - Dollies/Single Axle



AQ919342
Shown

PLC Select 2M supports 4S/2M and 2S/2M applications

PART #	DESCRIPTION
AL919342	PLC Select 2M ECU - DIN 12V - SLH-A7 - Multi-Axle

Loom Assemblies

- ECU end has a 19 or 28-Pin connector that interfaces with matching connector on the ECU
- Trailer end includes 2 or 4 sensor leads and 1 or 2 valve leads depending on the ABS configuration and a power lead with industry 5-pin male connector



PLC 2S/1M Loom

**PRODUCTION from
MARCH 2001 to Present**



PLC 4S/2M Loom

PART #	DESCRIPTION
AL40900	2S/1M PLC - SLH-A7 - 19 Pin - 2 Keys-Diagonal
AL40901	2S/1M PLC - SLH-A8 - 19 Pin - 2 Keys-Across
AL40906	4S/2M PLC - 19 Pin - No Keys

Note: PLC Plus platform discontinued. Upgrade to new technology with the ECU upgrade kits. **AQ964110** replaces AL40953 and AL40957. **AQ964111** replaces AL956100, AL956104 and AL956108.

ABS Sensors, Kits, Blocks

SENSORS WITH RETAINER CLIP

Sensor - 90° Body - With Clip

PART #	Length
AL10271914	1.6 Feet (0.5m)
AL364068	4.0 Feet (1.25m)
AL364069	5.0 Feet (1.75m)
AL364061	4.9 Feet (1.5m)
AL10271915	6.6 Feet (2m)
AL364070	7.0 Feet (2.25m)
AL364062	8.2 Feet (2.5m)
AL364071	9.0 Feet (3m)
AL364063	11.5 Feet (3.5m)
AL364053	13.1 Feet (4m)



Sensor - 90° Body - With Clip and Block

PART #	Length
AQ40213	6.6 Feet (2m)



Sensor - Straight Body - With Clip

PART #	Length
AL1027196	1.6 Feet (0.5m)
AL1027197	6.6 Feet (2m)
AL1027198	13.1 Feet (4m)

- NOTES: 1. Sensors supplied with **A59512309** Retainer Clip.
2. Longer lengths may be used; secure excess to trailer.

SENSOR ACCESSORIES

PART #	DESCRIPTION
A59512309	Sensor Block Retainer
A902700	Tractor/Trailer ABS Retainer
A920802	Sensor Block (Trailer)

UNIVERSAL SENSOR EXTENSIONS

- ECU end has 2-Pin female connector
- Sensor end has 2-Pin male connector

PART #	Length
AL919800	1.6 Feet (0.5m)
AL919801	3.3 Feet (1m)
AL919802	4.9 Feet (1.5m)
AL919803	6.6 Feet (2m)
AL919804	8.2 Feet (2.5m)
AL919805	9.8 Feet (3m)
AL919806	11.5 Feet (3.5m)
AL919807	13.1 Feet (4m)
AL919808	16.4 Feet (5m)
AL919809	19.7 Feet (6m)
AL919810	26.2 Feet (8m)
AL919811	32.8 Feet (10m)



Haldex offers a complete line of ABS Power Cords, Extensions, Adapter Cables, Diagnostic Equipment and associated ABS Hardware. Please consult the Haldex Master Catalog (www.haldex.com) for our complete listing.

Remanufactured Clutches - 13"

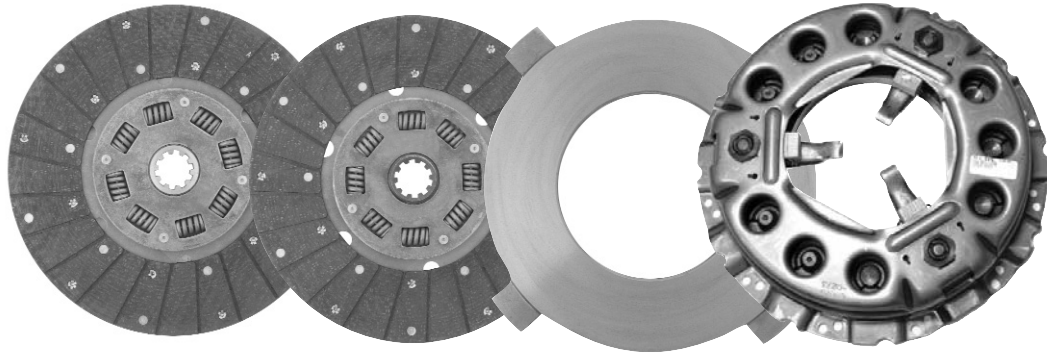

LIPE PUSH TYPE CLUTCH - 13" SINGLE PLATE - FLAT FLYWHEEL

REMAN PACK #	COVER ASSEMBLY	DISC ASSEMBLY	DISC TYPE	SPLINE SIZE	MAX TORQUE	BOLT CIRCLE	APPLICATION
RC1933114X	RC3301933X	130-009-1802	DAMP ORGANIC	1.25" - 10T	350	14.125/14.625	NAVISTAR
RC1933117X	RC3301933X	130-009-1902	DAMP CERAMIC	1.25" - 10T	600	14.125/14.625	NAVISTAR
RC1933134X	RC3301933X	130-009-1135	DAMP ORGANIC	1.5" - 10T	350	14.125/14.625	PERKINS
RC1935136X	RC3301935X	330-009-1865	DAMP CERAMIC	1.5" - 10T	500	375mm/14.764	RENAULT
RC1938124X	RC3301938X	130-009-1803	DAMP ORGANIC	1.38" - 10T	350	14.125/14.625	FORD/DODGE
RC1938127X	RC3301938X	130-009-1903	DAMP CERAMIC	1.38" - 10T	350	14.125/14.625	FORD/DODGE
RC1938134X	RC3301938X	130-009-1135	DAMP ORGANIC	1.5" - 10T	350	14.125/14.625	CHEV/GMC
RC1938137X	RC3301938X	130-009-1904	DAMP CERAMIC	1.5" - 10T	500	14.125/14.625	CHEV/GMC
RC2077136X	RC3302077X	330-009-2078	DAMP CERAMIC	1.5" - 10T	500	14.125/14.625	CAT 3116/3126 ENG.

LIPE PUSH TYPE CLUTCH - 13" TWO PLATE - 1.062 RECESS FLYWHEEL

REMAN PACK #	COVER ASSEMBLY	DISC ASSEMBLY	DISC TYPE	INTER. PLATE	SPLINE SIZE	MAX TORQ.	BOLT CIRCLE	APPLICATION
RC1931134X	RC3301931X	130-009-1134 (FWS) 130-009-1135 (PPS)	DAMP ORG.	C025-0094	1.5" - 10T	350	14.125/14.625	CUMMINS
RC1931144X	RC3301931X	130-009-1136 (FWS) 130-009-1137 (PPS)	DAMP ORG.	C025-0094	1.75" - 10T	600	14.125/14.625	CUMMINS
RC1937134X	RC3301937X	130-009-1134 (FWS) 130-009-1135 (PPS)	DAMP ORG.	C025-0094	1.5" - 10T	600	14.125/14.625	CHEV/GMC CUMMINS
RC1989134X	RC3301989X	130-009-1134 (FWS) 130-009-1135 (PPS)	DAMP ORG.	C025-0094	1.5" - 10T	600	14.125/14.625	NAVISTAR FORD
RC1989138X	RC3301989X	130-009-1530 (FWS) 130-009-1531 (PPS)	DAMP CER.	C025-0094	1.5" - 10T	750	14.125/14.625	NAVISTAR FORD

LIPE PUSH TYPE CLUTCH - 13" TWO PLATE - 1.478 RECESS FLYWHEEL

REMAN PACK #	COVER ASSEMBLY	DISC ASSEMBLY	DISC TYPE	INTER. PLATE	SPLINE SIZE	MAX TORQ.	BOLT CIRCLE	APPLICATION
RC1940132X	RC3301940X	130-006-0830	RIGID ORG.	C025-0096	1.5" - 10T	-	-	FORD GAS
RC1940136X	RC3301940X	130-009-1530 (FWS) 130-009-1531 (PPS)	DAMP CER.	C025-0096	1.5" - 10T	-	-	FORD GAS
RC1941134X	RC3301941X	130-009-1134 (FWS) 130-009-1135 (PPS)	DAMP ORG.	C025-0094	1.5" - 10T	600	14.500	CAT 3208

NOTE: Replacement Disc Assemblies Available in New Only.

Remanufactured Clutches - 14"

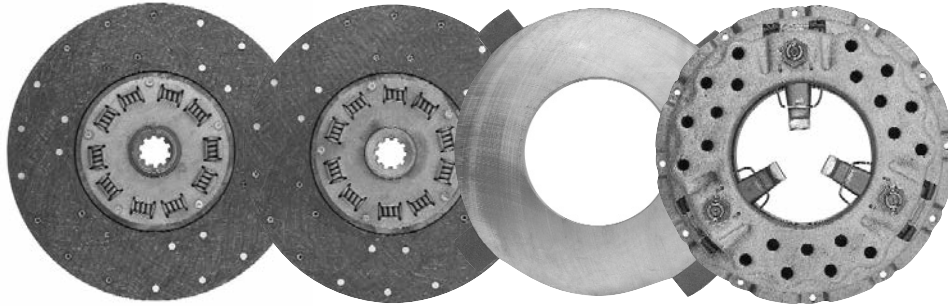

LIPE PUSH TYPE CLUTCH - 14" SINGLE PLATE - FLAT FLYWHEEL

REMAN PACK #	COVER ASSEMBLY	DISC ASSEMBLY	DISC TYPE	SPLINE SIZE	MAX TORQUE	BOLT CIRCLE	APPLICATION
RC1047604X	RC141047X	140-009-1027	DAMP ORGANIC	1.5" - 10T	500	15.500	CHEV/GMC/FORD
RC1086604X	RC141086X	140-009-1027	DAMP ORGANIC	1.5" - 10T	500	15.500	NAVISTAR
RC1686607X	RC141686X	140-009-2208	DAMP CERAMIC	1.5" - 10T	500	15.500	CHEV/GMC DIESEL
RC1686640	RC141686X	140-009-1998	DAMP CERAMIC	1.5" - 10T	500	15.500	CHEV/GMC GAS

LIPE PUSH TYPE CLUTCH - 14" TWO PLATE - 1.062 RECESS FLYWHEEL

REMAN PACK #	COVER ASSEMBLY	DISC ASSEMBLY	DISC TYPE	INTER. PLATE	SPLINE SIZE	MAX TORQ.	BOLT CIRCLE	APPLICATION
RC1072604X	RC141072X	140-009-2355 (FWS) 140-009-2356 (PPS)	DAMP ORG.	C025-0100	1.5" - 10T	600	15.500	FORD
RC1072607X	RC141072X	140-009-2357 (FWS) 140-009-2208 (PPS)	DAMP CER.	C025-0100	1.5" - 10T	900	15.500	FORD

LIPE PUSH TYPE CLUTCH - 14" TWO PLATE - 1.093 RECESS FLYWHEEL

REMAN PACK #	COVER ASSEMBLY	DISC ASSEMBLY	DISC TYPE	INTER. PLATE	SPLINE SIZE	MAX TORQ.	BOLT CIRCLE	APPLICATION
RC1067645X	RC141067X	140-009-2303 (FWS) 140-009-2304 (PPS)	DAMP ORG.	C025-0100	1.75" - 10T	1000	15.625	VARIOUS CRANE
RC1067646X	RC141067X	140-009-2299 (FWS) 140-009-2300 (PPS)	DAMP CER.	C025-0100	1.75" - 10T	1200	15.625	VARIOUS CRANE
RC1113604X	RC141113X	140-009-2212 (FWS) 140-009-2213 (PPS)	DAMP ORG.	C025-0100	1.75" - 10T	750	15.500	CHEV/GMC
RC1113606X	RC141067X	140-009-2210 (FWS) 140-009-2211 (PPS)	DAMP CER.	C025-0100	1.75" - 10T	1000	15.500	CHEV/GMC
RC1113649X	RC141113X	140-009-2303 (FWS) 140-009-2304 (PPS)	DAMP ORG.	C025-0100	1.75" - 10T	750	15.500	CATERPILLAR

NOTE: Replacement Disc Assemblies Available in New Only. Rigid Discs Not Recommended.

EZ N LITE® New/Remanufactured Clutches

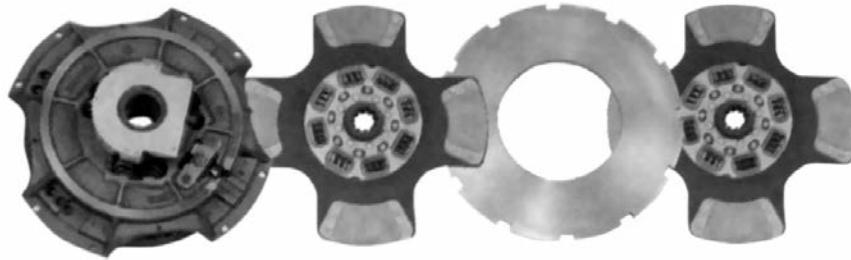

EZ N LITE® - 14" TWO PLATE, 2.937" POT FLYWHEEL

NEW PACK #	REMAN PACK #	DISC TYPE	SPLINE SIZE	WEIGHT	SUGGESTED APPLICATION
N10705059*	RC390DCX	DAMP CERAMIC	2" - 10T	103 LBS.	VARIOUS
N10703482**	RC390DOX	DAMP ORGANIC	2" - 10T	105 LBS.	VARIOUS

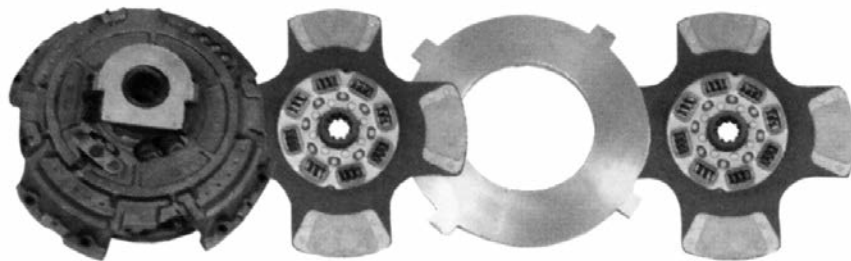

EZ N LITE® - 15 1/2" TWO PLATE, FLAT FLYWHEEL

NEW PACK #	REMAN PACK #	DISC TYPE	SPLINE SIZE	WEIGHT	SUGGESTED APPLICATION
N10709181*	RC597DCX	DAMP CERAMIC	2" - 10T	137 LBS.	VARIOUS
N10839182**	RC597DOX	DAMP ORGANIC	2" - 10T	139 LBS.	VARIOUS
N10839174*	RC018EZX	10 SPRING CERAMIC	2" - 10T	143 LBS.	CAT 3406B DDA 60 SERIES
N10893551*	RC698EZX	9 SPRING CERAMIC	2" - 10T	146 LBS.	EARLY MACK LATE MACK
N10892582*	RC700EZX	7 SPRING CERAMIC	2" - 10T	142 LBS.	E6-E7 CUMMINS N-14

* Disc Facing - Carbotic

** Disc Facing - Organic

EZ N LITE® (Cont.) and COOL N EZ® Angle Spring Clutches

NEW COOL N EZ®	EATON / SPICER	REMAN STD ANGLE SPR	REMAN EASY-PEDAL™	REMAN STD ANGLE SPR	REMAN EASY-PEDAL™	NEW COOL N EZ®	EATON / SPICER	REMAN STD ANGLE SPR	REMAN EASY-PEDAL™				
N108935-91	108935-94	2	4000	9	6 Pad - Carbotic	1760	PL1632	10'	N128537C	N128538C	A8	NA	RC688EZC
N108935-92	108935-95	2	4000	10	Organic	1450	PL1631	8.5'	N128445	N128446	A2	N10739178	RC018EZDOX
N108935-93	108935-96	2	4000	10	4 Pad - CB	1650	PL1632	8.5'	N128257	N128258	A6	N10709174	RC018EZ
N108935-94	108935-97	2	4000	10	4 Pad - Carbotic	1650	PL1632	8.5'	N128257C	N128258C	A6	N10739174C	RC018EZC
N108935-95	108935-98	2	4000	10	6 Pad - CB	1860	PL1632	8.5'	N128639	N128640	A9	N10709193H	RC018EZHTX
N108935-96	108935-99	2	4000	10	6 Pad - Carbotic	1860	PL1632	8.5'	N128539C	N128540C	A9	NA	NA
N108935-97	108935-10	2	4000	7 NVL	6 Pad - CB	1860	PL1632	10'	N128708TM	N128708TM	A10	NA	RC892520EZ
N108935-98	108935-11	2	4000	7 NVL	6 Pad - CB	2050	PL1632	10'	N128709TM	N128709TM	A10	NA	RC892525EZ
N108935-99	108935-12	2	4000	7 NVL	6 Pad - CB	2250	PL1632	10'	N128709HTM	N128709HTM	A10	NA	RC892529HEZX
N108935-10	108935-13	2	4000	7+4 PDHT	6 Pad - CB	1860	PL1632	10'	N128716TM	N128716TM	A11	NA	RC892530EZ
N108935-11	108935-14	2	4000	7+4 PDHT	6 Pad - CB	2050	PL1632	10'	N128717TM	N128717TM	A11	NA	RC892535EZ
N108935-12	108935-15	2	4000	7+4 PDHT	6 Pad - CB	2250	PL1632	10'	N128717HTM	N128717HTM	A11	NA	RC892539HEZX
N108935-13	108935-16	2	4000	9	6 Pad - CB	2250	PL1632	10'	CD-128570H	CD-128571H	-	NA	NA

TORQUEMONSTER

NEW COOL N EZ® ANGLE SPRING CLUTCHES

NEW COOL N EZ®	EATON / SPICER	REMAN STD ANGLE SPR	REMAN EASY-PEDAL™
N10768316CE	107683-16	RC747DOX	NA
N1076835CE	107683-5	NA	NA
N1079151CE	107915-1	RC747DCX	NA
N1076879CE	107687-9	NA	NA

NEW COOL N EZ® (2 PLATE) Includes Adaptor Ring & Center Plate - PL1480AR

NEW COOL N EZ®	EATON / SPICER	REMAN STD ANGLE SPR	REMAN EASY-PEDAL™
N10770118CE	107701-18	RC044STD0X	NA
N10723710CE	107237-10	NA	NA
N10723722CE	107237-22	RC044STD0X	NA
N10723742CE	107237-24	NA	NA

NEW COOL N EZ® (2 PLATE) Includes Adaptor Ring & Center Plate - PL1480AR

NEW COOL N EZ®	EATON / SPICER	REMAN STD ANGLE SPR	REMAN EASY-PEDAL™
N10770316CE	107703-16	RC065STD0X	NA
N1073424CE	107342-4	NA	NA
N1073422CE	107342-22	NA	NA
N1073424CE	107342-24	NA	NA

14" X 1 3/4" X 10 (SINGLE PLATE)

No. of Discs	Plate Load	Disc Springs	Disc Facing	Max Torque Lbs. Ft.	Center Plate Part #	Flywheel Diameter	Front Disc Part #	Rear Disc Part #
1	3200	8	Organic	445	N/A	7"	N127262	N/A
1	3200	8	3 Pad - CB	620	N/A	7"	N128276	N/A
1	3200	8	4 Pad - CB	650	N/A	7"	N127405	N/A
1	3200	8	6 Pad VTL - CB	680	N/A	7"	N128573	N/A

14" X 1 3/4" X 10 (2 PLATE)

No. of Discs	Plate Load	Disc Springs	Disc Facing	Max Torque Lbs. Ft.	Center Plate Part #	Flywheel Diameter	Front Disc Part #	Rear Disc Part #
2	2800	8	Organic	800	PL1480AR	7"	N127261	N127262
2	2800	8	3 Pad VTL - CB	860	PL1480AR	7"	N128578	N128579
2	2800	8	3 Pad - CB	860	PL1480AR	7"	N128275	N128276
2	2800	8	4 Pad - CB	860	PL1480AR	7"	N127404	N127405

14" X 2" X 10 (2 PLATE)

No. of Discs	Plate Load	Disc Springs	Disc Facing	Max Torque Lbs. Ft.	Center Plate Part #	Flywheel Diameter	Front Disc Part #	Rear Disc Part #
2	2800	8	Organic	800	PL1480AR	7"	N128238	N128239
2	2800	8	3 Pad VTL - CB	860	PL1480AR	7"	N128594	N128595
2	2800	8	3 Pad - CB	900	PL1480AR	7"	N128231	N128232
2	2800	8	4 Pad - CB	1000	PL1480AR	7"	N128229	N128230

*Carbotic Discs Available!

Ceramic
 N10892520TM
 N10892525TM
 N10892525HTM
 N10892530TM
 N10892535TM
 N10892535HTM
 N10893592HTM

Carbotic
 N10892520CTM
 N10892525CTM
 N10892525HCTM
 N10892530CTM
 N10892535CTM
 N10892535HCTM
 N10893592HCTM

Easy Pedal - Trademarked by Eaton Corp.

AUTO N EZ® Self-Adjusting Clutches

NEW AUTO N EZ® SELF ADJUSTING CLUTCHES

15 1/2" X 2" X 10 (2 PLATE)

AUTO N EZ®	EATON / SPICER		No. of Discs	Plate Load	Disc Springs	Disc Facing	Max. Torq. Lbs. Ft.	Center Plate Part#	Flywheel Diameter	Frnt Disc Part# (Flywhl Side)	Rear Disc Part# (Press Plate Side)
N10970182	109701-82	109701-86	2	3600	7	4 Pad - CB	1700	PL-1632	10"	N128462	N128462
	109700-82	109701-82									
	109701-80	109701-14									
	109701-84	-									
N10970185	109701-85	109700-85	2	3600	7	6 Pad - CB	1700	PL-1632	10"	N129462	N129462
N10970277	109702-77	-	2	3600	8	Organic	1250	PL-1632	7"	N127817	N127818
N10970181	109701-81	109701-59	2	3600	8	4 Pad - CB	1400	PL-1632	7"	N128215	N128216
	109700-81	-									
N10970061	109700-51	109700-61	2	3600	9	4 Pad - CB	1760	PL1632	10"	N128362	N128363
N10970092	109700-91	109700-92	2	3600	9	6 Pad - CB	1760	PL1632	10"	N128537	N128538
N10970078	109700-78	-	2	4000	10	Organic	1450	PL1632	8.5"	N128445	N128446
N10970174	109701-74	109700-74	2	3600	10	4 Pad - CB	1650	PL-1632	8.5"	N128257	N128258
N10970193	109701-93	109700-95	2	4000	10	6 Pad - CB	1860	PL-1632	8.5"	N128539	N128540
	109700-93	109700-9									
TORQUEMONSTER											
N10970120TM	109701-20	109700-5	2	4000	7 NVL	6 Pad - CB	1860	PL-1632	10"	N128708TM	N128708TM
	109700-21	109700-10									
	109701-19	109701-10									
N10970125TM	109701-25	109700-15	2	4000	7 NVL	6 Pad - CB	2050	PL-1632	10"	N128709TM	N128709TM
	109700-25	109701-15									
	109701-26	-									
N10970125HTM	-	-	2	4000	7 NVL	6 Pad - CB	2250	PL1632	10"	N128709HTM	N128709HTM
N10970130TM	109701-24	109701-30	2	4000	7+4 PDHT	6 Pad - CB	1860	PL1632	10"	N128716TM	N128716TM
	109701-29	-									
N10970135TM	109701-35	109701-36	2	4000	7+4 PDHT	6 Pad - CB	2050	PL1632	10"	N128717TM	N128717TM
N10970135HTM	-	-	2	4000	7+4 PDHT	6 Pad - CB	2250	PL-1632	10"	N128717HTM	N128717HTM

**For additional clutch information please see
L00144 Clutch Application Guide on the
Haldex website (www.Haldex.com).**

Most Haldex Remanufactured Parts are also available in New and CoreFree®.
Please consult the Haldex Master Catalog (www.haldex.com) for our complete listing.

Remanufactured Alternators



RA121000X/RA122001X

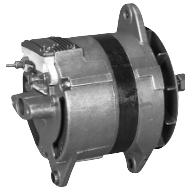

RA228000X

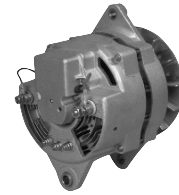

RA403000X

REMANUFACTURED DELCO ALTERNATORS

PART #	TYPE	VOLTAGE	AMPS	POLARITY	DELCO REMAN #
RA121000X	21-SI	12	100	Negative	10459013
RA122001X	22-SI	12	130	Negative	10459189

REMANUFACTURED LEECE-NEVILLE ALTERNATORS

PART #	TYPE	VOLTAGE	AMPS	POLARITY	LEECE-NEVILLE MFG #
RA228000X	JB Series	14	160	Pos./Neg.	2800JB

REMANUFACTURED MOTOROLA ALTERNATORS

PART #	TYPE	VOLTAGE	AMPS	POLARITY	MOTOROLA MFG #	NOTES
RA403000X	10-255 & 10-555	12	130	Insul.	8LHA2023V	Pos./Neg. Ground

Remanufactured Delco Starters

PART #	TYPE	VOLTAGE	ROTATION	PINION TEETH	SWITCH POSITION	DELCO REMAN #
RS137000X	37-MT	12	CW	12	068°	10461089
RS140001X	40-MT	12	CW	11	052°	10461045
RS142001X	42-MT	12	CW	11	082°	10461052
RS142002X	42-MT	12	CW	12	082°	10461414



RS140001X



RS142001X

Remanufactured Fan Clutches

REMANUFACTURED HORTON FAN CLUTCHES

PART #	MODEL	ENGINE
RF790000X	Clutch S	Cummins NTC, NT, 444
RF790007X	Clutch S	Caterpillar 3406
RF790010X	Clutch S	Cummins L-10, NTC
RF791000X	Clutch HT/S	Cummins NTC, NT88, N14

GOLD TOP® FAN CLUTCH REBUILD KITS

PART #	DESCRIPTION
RF14200K	2" Pilot; 2 Pulley Bearings
RF14256K	2.56" Pilot; 2 Pulley Bearings



Most Haldex Remanufactured Parts are also available in New and CoreFree®.
Please consult the Haldex Master Catalog (www.haldex.com) for our complete listing.

Remanufactured Lucas Girling Hydraulic Brake Calipers



BENDIX® 2.88" Twin Piston - Chev/GMC/Navistar

CALIPER ONLY	LOADED KIT	SEMI-LOADED KIT	CASTING NUMBER	SHIM KIT	HARDWARE KIT
RH55250X	RH55250LLX (left) RH55250RLX (right)	RH55250SX	4150844	SK225K	RH5635K



DAYTON 2.50" Twin Piston - Chev/GMC/Ford

CALIPER ONLY	LOADED KIT	SEMI-LOADED KIT	CASTING NUMBER	SHIM KIT	HARDWARE KIT
RH55251X	RH55251LX	RH55251SX	472	SK224K	RH5636K



BENDIX® 2.60" Twin Piston - Navistar

CALIPER ONLY	LOADED KIT	SEMI-LOADED KIT	CASTING NUMBER	SHIM KIT	HARDWARE KIT
RH55314X	RH55314LX	RH55314SX	4151733	SK225K	RH5634K



REMANUFACTURED IN THE USA



Most Haldex Remanufactured Parts are also available in New and CoreFree®.
Please consult the Haldex Master Catalog (www.haldex.com) for our complete listing.

Air Control Valves



Sprague Compatible
Part # RM1115001



Trico Compatible
Part # RM1650001

Air Wiper Motors

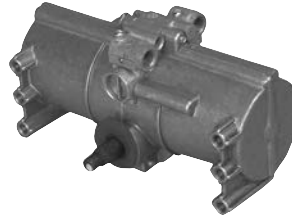

Part # RM2598001X



Part # RM3495001X

Remanufactured Haldex/Competitive Master Cylinders and Vacuum Boosters



Bendix® Vacuum Booster
Part # RV2503259x

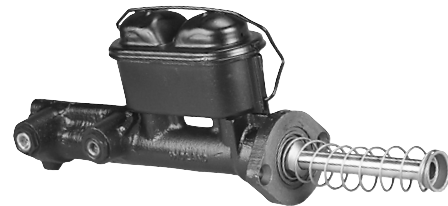

Midland Master Cylinder
Part # RV350002X

All Makes Remanufactured Steering Gears & Pumps

- For Caterpillar, Cummins, Detroit Diesel, Ford, General Motors, Mack, Navistar and Thermo-King Engines.

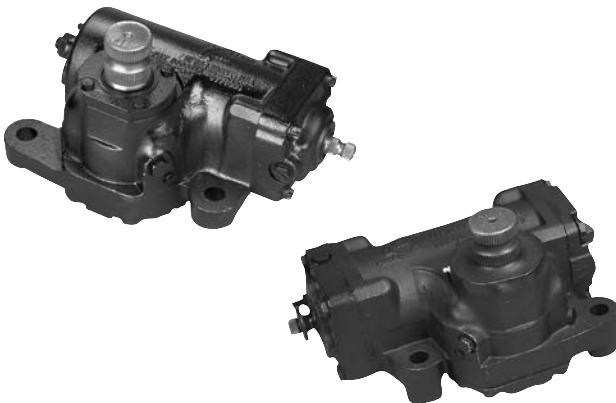

- Haldex offers TRW, Saginaw, Hobourn/Eaton, Vickers and Parker Hannifin.

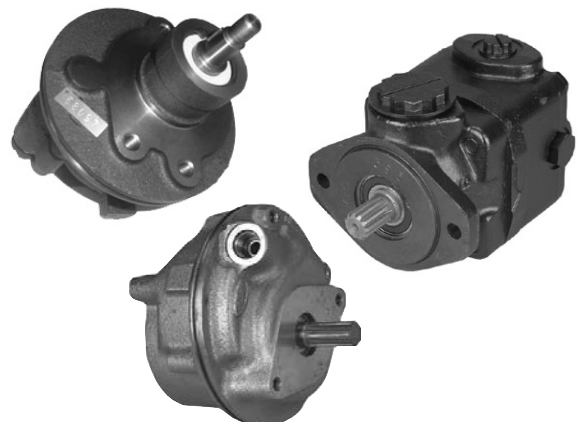

Brake Hardware Kits

12 1/4" TRAILER KITS

PART #	DESCRIPTION
CQ67398	Dana Spicer - Late Model, for Fabricated Shoes and Weld on Spider
CQ69002	Dana Spicer - New Style U-Brake 1 1/4" Diameter Roller
CQ69006	Dana Spicer - New Style U-Brake 1 1/2" Diameter Roller
CQ67437	Dana Spicer - FC 1996 and newer 1 1/2" Roller and 1 1/4" Anchor Pin
CQ65620	Dexter - PQ Style May 1996 and newer
CQ67395	Meritor - "Q" Series Brakes



CQ67395

15" STEER AXLE KITS

PART #	DESCRIPTION
CQ66917	Eaton - Single Anchor Pin Front Axle Brakes
CQ66919	Meritor - T-Series Front Axle Brakes
CQ69003	Meritor - T-Series, Minor Kit
CQ69001	Meritor - "Q" Series Front Axle Brakes - Single Web
CQ67899	Meritor - "Q" Series, Minor Kit
CQ65642	Meritor - "Q-Plus" Series Brakes



CQ67899

16 1/2" BRAKE HARDWARE KITS

PART #	DESCRIPTION
CQ67390	Meritor - "P" Series Captive Anchor Pin
CQ65444	Eaton - "ES" Combination Kit
CQ65445	Eaton - "ESII" Combination Kit
CQ65481	Eaton - "ES" 1st Generation
CQ65477	Eaton - "ESII" 2nd Generation
CQ65479	Eaton - "ES" for Meritor
CQ67319	Eaton - Single Anchor Pin Heavy Duty
CQ66914	Fruehauf - "XEM" & "FQ" Heavy Duty
CQ66913	Fruehauf - "XEM" & "FQ" Standard Duty
CQ66867	Meritor - "Q" & "Q" Plus Heavy Duty
CQ66861	Meritor - "Q" & "Q" Plus Standard Duty
CQ66887	Meritor - "Q", "Q" Plus and "Q" Mack with Hammer Claw Camshaft
CQ69005	Meritor - "Q" Mack Application



CQ66867

Consult the Haldex Master Catalog (www.haldex.com) for a complete listing of Friction Products Offered.

Brake Block Descriptions

GG BRAKE BLOCK

Friction CodeFF
 Material Type2020
 Brake Type“S” Cam
 GAWR23,000 lbs.

GR BRAKE BLOCK

Friction CodeFF
 Material Type2015
 Brake Type“S” Cam
 GAWR20,000 lbs.

GH BRAKE BLOCK

Friction CodeFF
 Material Type2023
 Brake Type“S” Cam
 GAWR23,000 lbs.

GF BRAKE BLOCK

Friction CodeFF
 Material Type2008
 Brake Type“S” Cam
 GAWR20,000 lbs.

GD BRAKE BLOCK

Friction CodeFF
 Material Type2016
 Brake Type“S” Cam
 GAWR23,000 lbs.

GN BRAKE BLOCK

Friction CodeFF
 Material Type2017
 Brake Type“S” Cam
 GAWR20,000 lbs.

HV88 BRAKE BLOCK

Friction CodeFF
 Material TypeHV88
 Brake Type“S” Cam
 GAWR23,000 lbs.

HV77 BRAKE BLOCK

Friction CodeFF
 Material TypeHV77
 Brake Type“S” Cam
 GAWR20,000 lbs.

GC BRAKE BLOCK

Friction CodeFF/FF
 Material TypeGG/GZ Combination
 Brake Type“S” Cam
 GAWR23,000 lbs.

GM BRAKE BLOCK

Friction CodeFF
 Material Type2040 Semi-Metallic
 Brake Type“S” Cam
 GAWR25,000 lbs.

GP BRAKE BLOCK

Friction CodeGG
 Material Type2030
 Brake Type“S” Cam
 GAWR25,000 lbs.

GZ BRAKE BLOCK

Friction CodeFF
 Material Type2035 Semi-Metallic
 Brake Type“S” Cam
 GAWR23,000 lbs.

GW (WEDGE) BRAKE BLOCK

Friction CodeGG
 Material Type2025
 Brake TypeWedge
 GAWR20,000 lbs.

TRANSIT BLOCK

TC Combination

Friction CodeFF
 Brake Type“S” Cam
 GAWR23,000 lbs.

Lined Shoe Descriptions

PART NUMBER FORMAT

GG 4515 Q R

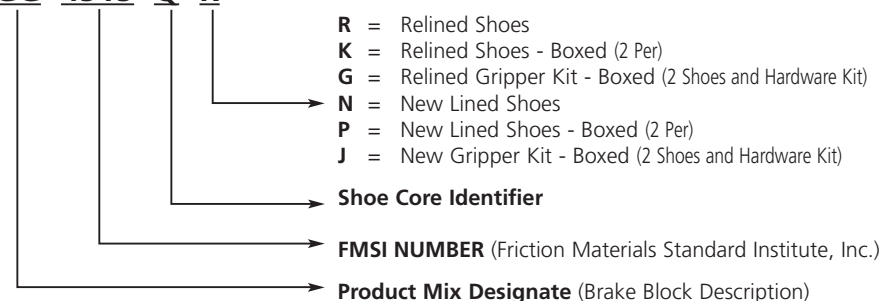

Eaton - Air/Single Web Brakes

15" x 4" Standard Steer Axle

- Rivet hole spacing across width (Center to Center) 2 3/4"
- Hardware Kit Part #CQ66917



Width	FMSI #	Shoe I.D.	Core Group
4"	1308	E	1308E

Relined Shoe	Relined Shoes Boxed (2 Per)	Relined-Gripper Kit With CQ66917	New Lined Shoe	New Shoes Boxed (2 Per)	New-Gripper Kit With CQ66917
GC1308ER	GC1308EK	GC1308EG	GC1308EN	-	GC1308EJ
-	-	-	GF1308EN	-	GF1308EJ
GG1308ER	GG1308EK	GG1308EG	GG1308EN	-	GG1308EJ
GR1308ER	GR1308EK	GR1308EG	GR1308EN	-	GR1308EJ
TS1308ER	-	TS1308EG	-	-	-

15" x 4" Extended Service Steer Axle

- Rivet hole spacing across width (Center to Center) 2"
- Hardware Kit Part #CQ66917



Width	FMSI #	Shoe I.D.	Core Group
4"	1443	E	1443TD

Relined Shoe	Relined Shoes Boxed (2 Per)	Relined-Gripper Kit With CQ66917	New Lined Shoe	New Shoes Boxed (2 Per)	New-Gripper Kit With CQ66917
GC1443ER	GC1443EK	GC1443EG	-	-	-
-	-	-	GF1443EN	-	GF1443EJ
GG1443ER	GG1443EK	GG1443EG	GG1443EN	-	GG1443EJ
GR1443ER	GR1443EK	GR1443EG	GR1443EN	GR1443EP	GR1443EJ
TS1443ER	-	TS1443EG	-	-	-

16 1/2" x 7" Low Mount

- Hardware Kit Part #CQ67319



Width	FMSI #	Shoe I.D.	Core Group
7"	4311	E	4311NS

Relined Shoe	Relined Shoes Boxed (2 Per)	Relined-Gripper Kit With CQ67319	New Lined Shoe	New Shoes Boxed (2 Per)	New-Gripper Kit With CQ67319
GC4311ER	GC4311EK	GC4311EG	GC4311EN	GC4311EP	GC4311EJ
GD4311ER	GD4311EK	GD4311EG	GD4311EN	-	GD4311EJ
GF4311ER	GF4311EK	GF4311EG	GF4311EN	GF4311EP	GF4311EJ
GG4311ER	GG4311EK	GG4311EG	GG4311EN	GG4311EP	GG4311EJ
GH4311ER	GH4311EK	GH4311EG	GH4311EN	GH4311EP	GH4311EJ
GM4311ER	-	GM4311EG	-	-	-
GN4311ER	GN4311EK	GN4311EG	GN4311EN	GN4311EP	GN4311EJ
GP4311ER	-	-	GP4311EN	-	-
GR4311ER	GR4311EK	GR4311EG	GR4311EN	GR4311EP	GR4311EJ
GZ4311ER	-	GZ4311EG	GZ4311EN	GZ4311EP	-

Consult the Haldex Master Catalog (www.haldex.com) for a complete listing of Friction Products Offered.

Eaton - Air/Double Web and Cast Brakes

16 1/2" x 7" Eaton "ES"

- Uses extended wear lining, cam and hardware
- Retainer springs attach to tabs on table anchor end
- Single Anchor Pin
- Hardware Kit Part #CQ65481
- Hardware Kit Part #CQ65444 available for steer axle



Width	FMSI #	Shoe I.D.	Core Group
7"	4709	ES	4709

Relined Shoe	Relined Shoes Boxed (2 Per)	Relined-Gripper Kit With CQ65481	New Lined Shoe	New Shoes Boxed (2 Per)	New-Gripper Kit With CQ65481
GC4709ESR	GC4709ESK	GC4709ESG	GC4709ESN	GC4709ESP	GC4709ESJ
GD4709ESR	-	GD4709ESG	GD4709ESN	-	GD4709ESJ
GF4709ESR	GF4709ESK	GF4709ESG	GF4709ESN	GF4709ESP	GF4709ESJ
GG4709ESR	GG4709ESK	GG4709ESG	GG4709ESN	GG4709ESP	GG4709ESJ
GH4709ESR	GH4709ESK	GH4709ESG	GH4709ESN	GH4709ESP	GH4709ESJ
GN4709ESR	GN4709ESK	GN4709ESG	GN4709ESN	-	GN4709ESJ
GP4709ESR	-	GP4709ESG	-	-	-
GR4709ESR	GR4709ESK	GR4709ESG	GR4709ESN	GR4709ESP	GR4709ESJ
GZ4709ESR	GZ4709ESK	GZ4709ESG	-	-	-

16 1/2" x 7" Eaton "ESII"

- Uses extended wear lining, cam and hardware
- Retainer springs attach on web
- Single Anchor Pin
- Hardware Kit Part #CQ65477
- Hardware Kit Part #CQ65445 available for steer axle



Width	FMSI #	Shoe I.D.	Core Group
7"	4709	ES2	4709NS

Relined Shoe	Relined Shoes Boxed (2 Per)	Relined-Gripper Kit With CQ65477	New Lined Shoe	New Shoes Boxed (2 Per)	New-Gripper Kit With CQ65477
GC4709ES2R	GC4709ES2K	GC4709ES2G	GC4709ES2N	GC4709ES2P	GC4709ES2J
GD4709ES2R	GD4709ES2K	GD4709ES2G	GD4709ES2N	-	GD4709ES2J
GF4709ES2R	GF4709ES2K	GF4709ES2G	GF4709ES2N	GF4709ES2P	GF4709ES2J
GG4709ES2R	GG4709ES2K	GG4709ES2G	GG4709ES2N	GG4709ES2P	GG4709ES2J
GH4709ES2R	GH4709ES2K	GH4709ES2G	GH4709ES2N	GH4709ES2P	GH4709ES2J
GN4709ES2R	GN4709ES2K	GN4709ES2G	GN4709ES2N	-	GN4709ES2J
GP4709ES2R	-	GP4709ES2G	-	-	-
GR4709ES2R	GR4709ES2K	GR4709ES2G	GR4709ES2N	GR4709ES2P	GR4709ES2J
GZ4709ES2R	GZ4709ES2K	GZ4709ES2G	GZ4709ES2N	-	GZ4709ES2J

Meritor - Air/Single Web Brakes

15" x 4" Meritor "Q" Late Style

- Late Style Shoe Table Located 1" Toward Anchor End
- Hardware Kit Part #CQ69001 or #CQ67899 minor kit



Width	FMSI #	Shoe I.D.	Core Group
4"	1308	Q2	1308TQN

Relined Shoe	Relined Shoes Boxed (2 Per)	Relined-Gripper Kit With CQ69001	Relined-Gripper Kit With CQ67899	New Lined Shoe	New Shoes Boxed (2 Per)	New-Gripper Kit With CQ69001
GC1308Q2R	GC1308Q2K	GC1308Q2G	GC1308Q2G2	GC1308Q2N	GC1308Q2P	GC1308Q2J
-	-	-	-	GF1308Q2N	-	GF1308Q2J
GG1308Q2R	GG1308Q2K	GG1308Q2G	GG1308Q2G2	GG1308Q2N	GG1308Q2P	GG1308Q2J
GR1308Q2R	GR1308Q2K	GR1308Q2G	GR1308Q2G2	GR1308Q2N	GR1308Q2P	GR1308Q2J
TS1308Q2R	-	TS1308Q2G	-	TS1308Q2N	-	-

15" x 4" Meritor "Q" Plus

- Double Web
- Hardware Kit Part #CQ65642



Width	FMSI #	Shoe I.D.	Core Group
4"	4702	Q	4702

Relined Shoe	Relined Shoes Boxed (2 Per)	Relined-Gripper Kit With CQ65642	New Lined Shoe	New Shoes Boxed (2 Per)	New-Gripper Kit With CQ65642
GC4702QR	GC4702QK	GC4702QG	GC4702QN	-	-
-	-	-	GF4702QN	-	GF4702QJ
GG4702QR	GG4702QK	GG4702QG	GG4702QN	-	GG4702QJ
GR4702QR	GR4702QK	GR4702QG	GR4702QN	-	GR4702QJ

16 1/2" x 7" Meritor "Q" Current Design

- Shoe has hump in web and inside rivet spacing across width of 2.75"
- Hardware Kit Part #CQ66867



Width	FMSI #	Shoe I.D.	Core Group
7"	4515	Q	4515TQN

Relined Shoe	Relined Shoes Boxed (2 Per)	Relined-Gripper Kit With CQ66867	New Lined Shoe	New Shoes Boxed (2 Per)	New-Gripper Kit With CQ66867
GC4515QR	GC4515QK	GC4515QG	GC4515QN	GC4515QP	GC4515QJ
GD4515QR	GD4515QK	GD4515QG	GD4515QN	-	GD4515QJ
GF4515QR	GF4515QK	GF4515QG	GF4515QN	GF4515QP	GF4515QJ
GG4515QR	GG4515QK	GG4515QG	GG4515QN	GG4515QP	GG4515QJ
GH4515QR	GH4515QK	GH4515QG	GH4515QN	GH4515QP	GH4515QJ
GM4515QR	-	GM4515QG	GM4515QN	-	-
GN4515QR	GN4515QK	GN4515QG	GN4515QN	GN4515QP	GN4515QJ
GP4515QR	-	GP4515QG	GP4515QN	-	GP4515QJ
GR4515QR	GR4515QK	GR4515QG	GR4515QN	GR4515QP	GR4515QJ
GZ4515QR	GZ4515QK	GZ4515QG	GZ4515QN	GZ4515QP	GZ4515QJ

Meritor - Air/Double Web and Cast Brakes

16 1/2" x 7" Meritor "Q" Plus

- Shoe has hump in web and inside rivet spacing across width of 2.75"
- Hardware Kit Part #CQ66867



Width	FMSI #	Shoe I.D.	Core Group
7"	4707	Q	4707

Relined Shoe	Relined Shoes Boxed (2 Per)	Relined-Gripper Kit With CQ66867	New Lined Shoe	New Shoes Boxed (2 Per)	New-Gripper Kit With CQ66867
GC4707QR	GC4707QK	GC4707QG	GC4707QN	GC4707QP	GC4707QJ
GD4707QR	GD4707QK	GD4707QG	GD4707QN	-	GD4707QJ
GF4707QR	GF4707QK	GF4707QG	GF4707QN	GF4707QP	GF4707QJ
GG4707QR	GG4707QK	GG4707QG	GG4707QN	GG4707QP	GG4707QJ
GH4707QR	GH4707QK	GH4707QG	GH4707QN	GH4707QP	GH4707QJ
GM4707QR	-	GM4707QG	-	-	-
GN4707QR	GN4707QK	GN4707QG	GN4707QN	-	GN4707QJ
GP4707QR	-	GP4707QG	GP4707QN	-	GP4707QJ
GR4707QR	GR4707QK	GR4707QG	GR4707QN	GR4707QP	GR4707QJ
GZ4707QR	-	GZ4707QG	GZ4707QN	-	GZ4707QJ

Haldex offers a complete line of Brake Shoes. Please consult the Haldex Master Catalog (www.haldex.com) for a detailed listing of the friction products offered.



Stop Burning Money

Save money and expensive fuel cost by installing the Haldex ILAS® III lift axle valve. The fully automatic valve responds to the pressure in the primary suspension air bags and will lift axles when they are not needed. The ILAS® valve is used for lowering and lifting one or more axles depending on the load applied to the vehicle.

Haldex provides solutions to improve the performance and efficiency of your vehicle. You can keep your vehicle on the road and maintain a lower cost of ownership by installing the Haldex ILAS® III lift axle valve.

Quit burning your money, specify Haldex Air Suspension components and keep your vehicle on the road.



www.haldex.com

ABS • Air Suspension Control • Air Treatment • Automatic Brake Adjusters • Friction • Spring Brakes



Thousands of Buses, Millions of Miles

Thousands of buses run millions of miles each year with premium Haldex air treatment products. Keep your fleet up and running by protecting your air brake system against moisture and contaminants. Major bus OEM's rely on the Haldex DRYest® and Consep™ to provide reliable performance and to ensure their transit systems are running each day.

Haldex air treatment products are effective in minimizing the build-up of water, oil and other contaminants while simultaneously reducing maintenance costs. Each product is designed for easy installation, reliability and long service life.

When it's time to spec an air treatment system, trust the reliable performance of Haldex air treatment products.



There's a new way to **STOP ROLLOVERS.**



Protect your fleet from rollovers.

Protect your fleet from costly and damaging rollovers with the new Haldex Trailer Rollover Stability System (TRS). The trailer-based TRS reduces the potential for combination vehicle rollovers by constantly monitoring the trailer's speed and lateral force 100 times per second. If a rollover is imminent, the TRS applies the trailer brakes to slow and stabilize the tractor/trailer. Controlling the potential for rollovers at the trailer is the most effective and economical choice.



www.haldex.com



Looks Can Be Deceiving ...

This Haldex Automatic Brake Adjuster was removed from an in-service trailer after 15 years as part of a standard refurbishment program. Although caked with grease and grime, it was tested and found to be 100% operational.

Each Haldex ABA is designed for optimum brake adjustment to help prevent uneven brake wear so you have fewer repairs, less downtime and less cost. It's also backed by the industry's best warranty.

Durability isn't always pretty. Demand Haldex ABA's on your next vehicle.



www.haldex.com

Inside back cover blank.

Haldex develops and provides reliable and innovative solutions that improve safety, vehicle dynamics and environmental sustainability in the global commercial vehicle industry. Listed on the Stockholm Stock Exchange, Haldex had net sales of approximately 4 billion SEK in 2011 and employs 2,350 people.

Disclaimer: The products described within this literature, including without limitation, product features, specifications, designs, availability and pricing are subject to change by Haldex and its subsidiaries at any time without notice.

This document and other information from Haldex, its subsidiaries and authorized distributors provide product and/or system options for further investigation by users having technical expertise. It is important that you analyze all aspects of your application and review the information concerning the product or system, in the current literature or catalog. Due to the variety of operating conditions and applications for these products or systems, the user, through their own analysis and testing, is solely responsible for making the final selection of the products and systems and assuring that all performance, safety and warning requirements are met.

©2012, Haldex AB - This material may contain Haldex trademarks and third party trademarks, trade names, corporate logos, graphics and emblems which are the property of their respective companies. The contents of this document may not be copied, distributed, adapted or displayed for commercial purposes or otherwise without prior written consent from Haldex.

Austria

Haldex Wien Ges.m.b.H.
Vienna
Tel.: +43 1 8 69 27 97
Fax: +43 1 8 69 27 97 27
E-Mail: info.AT@haldex.com

Belgium

Haldex N.V.
Balegem
Tel.: +32 9 363 90 00
Fax: +32 9 363 90 09
E-Mail: info.BE@haldex.com

Brazil

Haldex do Brazil
São Paulo
Tel.: +55 12 3935 4000
E-Mail: info.BR@haldex.com

Canada

Haldex Ltd.
Cambridge, Ontario
Tel.: +1 519 621 6722
Fax: +1 519 621 3924
E-Mail: info.CA@haldex.com

China

Haldex International Trading Co. Ltd.
Shanghai
Tel.: +86 21 5240 0338
Fax: +86 21 5240 0177
E-Mail: info.CN@haldex.com

France

Haldex Europe SAS
Weyersheim (Strasbourg)
Tel.: +33 3 88 68 22 00
Fax: +33 3 88 68 22 09
E-Mail: info.EUR@haldex.com

Germany

Haldex Brake Products GmbH
Heidelberg
Tel.: +49 6 221 7030
Fax: +49 6 221 703400
E-Mail: info.DE@haldex.com

Hungary

Haldex Hungary Kft.
Szentlőrincváta
Tel.: +36 29 631 300
Fax: +36 29 631 301
E-Mail: info.HU@haldex.com

India

Haldex India Limited
Nasik
Tel.: +91 253 2380094
Fax: +91 253 2380729

Italy

Haldex Italia Srl.
Biassono (Milan)
Tel.: +39 039 47 17 02
Fax: +39 039 27 54 309
E-Mail: info.IT@haldex.com

Korea

Haldex Korea Ltd.
Seoul
Tel.: +82 2 2636 7545
Fax: +82 2 2636 7548
E-Mail: info.HKR@haldex.com

Mexico

Haldex de Mexico S.A. De C.V.
Monterrey
Tel.: +52 81 8156 9500
Fax: +52 81 8313 7090

Poland

Haldex Sp. z.o.o.
Praszka
Tel.: +48 34 350 11 00
Fax: +48 34 350 11 11
E-Mail: info.PL@haldex.com

Russia

OOO "Haldex RUS"
Moscow
Tel.: +7 495 747 59 56
Fax: +7 495 786 39 70
E-Mail: info.RU@haldex.com

Spain

Haldex España S.A.
Granollers
Tel.: +34 93 84 07 239
Fax: +34 93 84 91 218
E-Mail: info.ES@haldex.com

Sweden

Haldex Brake Products AB
Landskrona
Tel.: +46 418 47 60 00
Fax: +46 418 47 60 01
E-Mail: info.SE@haldex.com

United Kingdom

Haldex Ltd.
Newton Aycliffe
Tel.: +44 1325 310 110
Fax: +44 1325 311 834
E-Mail: info.GBAy@haldex.com

Haldex Brake Products Ltd.

Redditch
Tel.: +44 1527 499 499
Fax: +44 1527 499 500
E-Mail: info.GBRe@haldex.com

USA

Haldex Brake Products Corp.
Kansas City
Tel.: +1 816 891 2470
Fax: +1 816 891 9447
E-Mail: info.US@haldex.com

